

# The Transmission-line Loudspeaker Enclosure

## A re-examination of the general principle and a suggested new method of construction

by A. R. Bailey\*, Ph.D., M.Sc., M.I.E.E.

Since the wool-filled transmission-line loudspeaker enclosure was first described † there has been a steadily increasing interest in its use.

The basic transmission-line enclosure is shown in Fig. 1. Radiation from the back of the driver cone flows down a pipe filled with a low-density sound-absorbing material. Fibrous absorbents such as loose wool, cotton wool and kapok can be used; sound absorption decreasing as the frequency goes down. In general it is very difficult to obtain good absorption if the path length is less than one-quarter wavelength of the sound in free-space; at 30Hz this corresponds to a path length of about 9ft.

If the pipe length is less than 9ft, sound at and below 30Hz will emerge from the open end of the pipe. Due to time delay in the pipe, the sound will not start to cancel the radiation from the front of the cone until the effective pipe-length is less than one-sixth of a wavelength. It is therefore possible to use the radiation from the open end of the pipe to reinforce that from the front of the loudspeaker cone at low frequencies

The effect of the wool filling in the pipe is to slow down the wave relative to its

\* University of Bradford

† Bailey, A. R., 'Non-resonant Loudspeaker Enclosure', *Wireless World*, Oct. 1965.

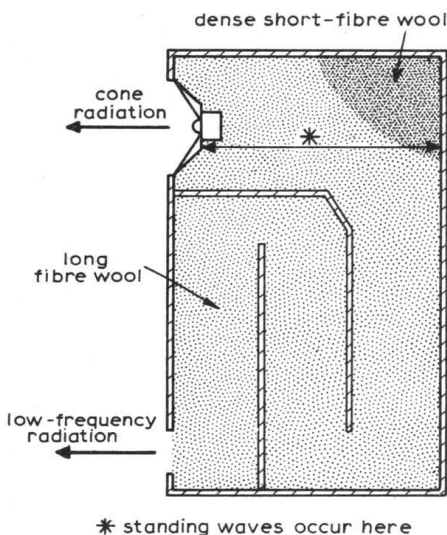

Fig. 1. Original transmission-line cabinet design.

velocity in free air. This reduction factor is between 0.7 and 0.8 for the recommended packing density, so the system will operate down to a somewhat lower frequency than would otherwise be expected.

The folding in the original cabinet design caused sound coloration due to reflections at the bends — particularly the first one at the back of the cabinet. The degree of coloration introduced by this first reflection (which, incidentally, is present in all plain box-shaped cabinets) was quite serious with the high crossover frequency of 1500Hz. Certainly the reproduction without it sounded as if an echo had been removed. The reasons for this were investigated.

In a simple closed box, as shown in Fig. 2, a sound impulse generated by the cone will have two components — the direct radiated pulse from the front of the cone and that propagated back into the cabinet. If this latter is assumed to be a plane wave, i.e. sound travelling parallel to the cabinet sides, it will strike the back wall and bounce back to the cone still as an impulse. Some of this energy will radiate through the cone to the outside and the remainder will be reflected back into the cabinet for re-reflection. The net result is a succession of steadily weakening pulses being radiated from the cabinet. The acoustic output will therefore be as shown in Fig. 3.

If the reflection from the back wall of the cabinet is changed so that it is gradual rather than abrupt, then the reflected wave will not be a unit impulse from an initiating unit impulse, but a pulse whose length and shape will depend on the nature of the reflection. This may be more readily appreciated by referring to Fig. 4. Here, the back wall of the cabinet is triangular. Sound radiated from the back of the cone is successively subjected to reflection, the first reflection occurring due to sound from the edge of the cone, and the last being due to that from the centre. As the path lengths for these reflections are very different, the sound in the cabinet will not emerge as a unit impulse but as a much lower amplitude long pulse — more like a continuous low level sound. This is subjectively far less noticeable to the ear than a series of decaying impulses. The two effects are compared in Fig. 5. Obviously, it would be far better to

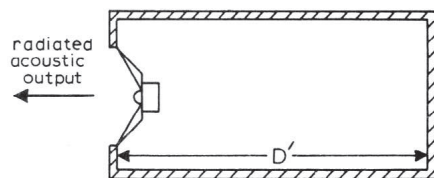

Fig. 2. Unlagged totally enclosed cabinet.

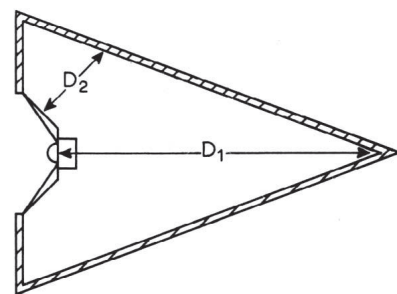
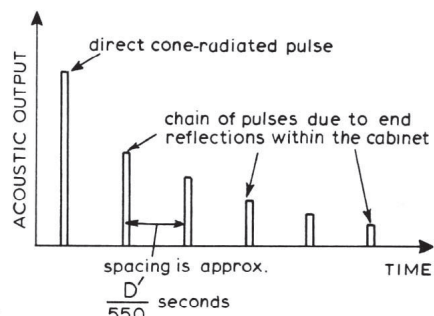

Fig. 4. Triangular cabinet showing different reflecting path lengths.

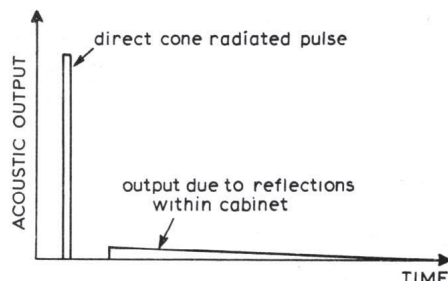

Fig. 5. Approximated output for triangular cabinet excited with impulse from loudspeaker.

absorb the sound completely on the back wall of the cabinet. Here we face the impossible, but it is imperative to make the best use of absorbent within the cabinet.

### Towards a solution

The basic requirement in using a forward facing loudspeaker unit is to guide the sound into the vertical direction without producing bad reflections. In addition the system must be fairly simple, to keep woodworking costs low, and also

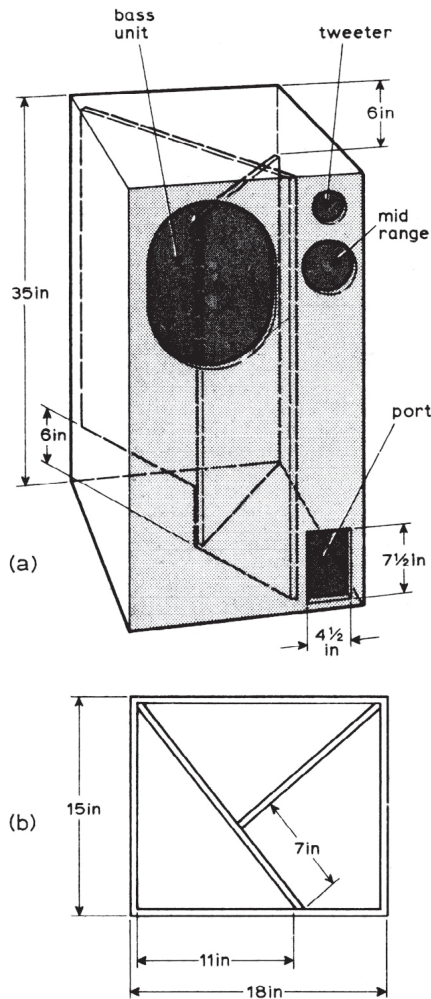

Fig. 6. Final design.

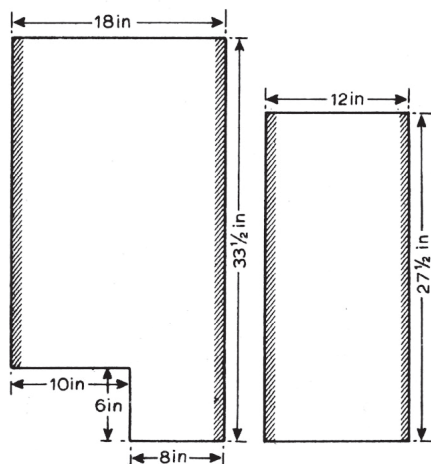

Fig. 7. Dimensions of internal partitions.

mechanically strong, to avoid significant panel resonances.

After experimenting with different cabinet shapes, the arrangement shown in Fig. 6 was arrived at. This has several advantages over the original design. First, the pipe is triangular in cross-section, thus giving less audible coloration due to reflections. Secondly, the woodwork is very simple; only two internal partitions are necessary. Thirdly, the front of the cabinet and the large partition are automatically braced so reducing panel resonance. Finally, sufficient area is available on the front of the cabinet to mount a mid-range unit in part of the line remote from the back of the bass driver when internal pressures are not too high. In practice, it has not been found necessary to use a separate enclosure for the mid-range unit.\*

Details of the partition sizes are shown in Fig. 7. A three-speaker system is recommended, as there is at present a difficult 'gap' between known low-coloration bass units and tweeters.

Incidentally, it should be noted that many 'high-fidelity' drive units are that in name only. Frequency-response is only one aspect of performance, and the transient response is far more important overall. Pulse or step testing loudspeakers in a long matched acoustic transmission line is most illuminating. Some units will still be radiating appreciable acoustic power 50ms after the exciting pulse has disappeared!

The units specified are known to have good transient response and are available with a suitable crossover network. Such networks are very difficult to design and it is not sufficient to use a general-purpose crossover unit. Unfortunately, loudspeakers do not behave as pure resistance at all frequencies — often quite the contrary. Design of crossovers from this assumption is completely incorrect and it is not uncommon for correct inductor sizes in a network to be double that expected from simple theory. In addition the different phase-angles of speakers at the crossover frequency complicates matters even more, and bad design can lead to abnormally low impedance levels over some parts of the frequency range. In short, crossover networks must be designed to operate with the speaker units that they are to be used with or very peculiar results can be obtained.

As previously, long-fibre wool is recommended as the continuous acoustic absorbent that fills the whole of the transmission line pipe. The wool must be well teased out or it loses its effectiveness. Anchoring the wool is something of a problem as it can compact with transport or use over a period. Nails or dowels projecting from the partitions will serve, but make stuffing difficult. The best suggestion yet made is to use a 'Netlon' core for the wool, fibres being teased through it and left sticking out all round. Using front-mounting loudspeakers as

\*However, there may be audible improvement if an absorbent filled enclosure is used behind the mid-range unit. ED.

### Recommended drive units and crossover networks

Bass driver	BD 25/1	£12.50
Mid-range unit	MD 9/2	£8.50
Tweeter	TD 3/2	£6.25
Crossover network	FN 10	£8.75
Radford Audio Ltd., Bristol BS3 2HZ.		

### Alternative units

Bass driver	B 139	£12.50
Mid-range	B 110	£7.80
Tweeter	T 27	£5.00
Crossover unit	DN 12	£4.50
K.E.F. Electronics Ltd., Tovil, Maidstone, Kent. (The performance with the K.E.F. units is improved if the Radford crossover is used in place of the K.E.F. crossover.) Long-fibre wool may be obtained from John W. Pennington (Dowley Gap) Ltd., Midland Wool Warehouses, Briggate, Windhill, Shipley, Yorks. The cost is 53p/lb including postage.		

specified, the two front pipes can be loaded through the speaker and port apertures, and the rear pipe is easily filled by removing the back of the cabinet. Alternatively, if the cabinet top is made removable all three pipes can be loaded from the top. A packing density of about ½lb per cubic foot is about right. Excess wool will cause back-pressures on the cone, and too little will cause pipe resonances in the low bass region.

What column resonance remains in the system can be reduced by putting 45-degree corner reflectors at the back of the speaker and also at each side of the first bend. These are not critical but should be so arranged that sound from the back of the cone will 'bounce' down the first pipe and then up the second, i.e. consider the sound to be light and the reflectors to be mirrors. The improvement is only about 1dB in frequency response when using reflectors, and as this improvement is only just detectable it may well be decided to omit them. If included, they should be made from ¾in chipboard or some similar material, and firmly fixed to the cabinet.

The port area is not critical as there is none of the tuning effect that occurs in the bass reflex enclosure. Changes in port area of two-to-one ratio produce no noticeable effect, but nevertheless it would be unwise to make the port much smaller than that given in the drawings as this is already considerably smaller in area than the pipe feeding it.

As mentioned previously, response curves should be treated with extreme caution as they represent only part of the performance of the speaker. Nevertheless the overall response curve should be as flat as is reasonably possible. The curve for the complete system when measured in an anechoic chamber is shown in Fig. 8.

In looking at this curve several points must be noted. First, the falling bass response shown will not occur in the same manner in a room. The presence of a floor will give a 3dB lift due to the absence of diffraction in the downward direction.

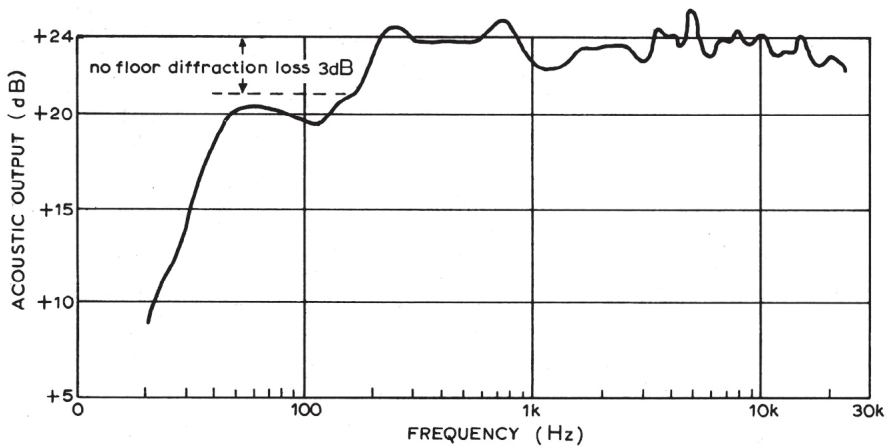

Fig.8. Anechoic response curve of complete loudspeaker system

Similarly, walls and ceilings add to the on-axis bass output. In fact a 'flat' response in an anechoic chamber will sound very bass heavy when the system is used in a normal room. Under normal room conditions the bass output of the system described is quite adequate, windows being easily rattled at 30Hz.

The smoothness of the overall curve is the most critical point, the odd decibel of gain or loss in overall response being far less important than a response with a smooth envelope. A jagged response curve means high Q components in the output and these are very noticeable on test. In fact a high Q resonance that lifts the

overall response by only 0.2dB may ruin the reproduction of an otherwise excellent speaker. Transient response testing is the ideal answer, but interpretation of the results is very difficult at present except on a rather empirical basis.

The ultimate test is the ear, but one must always remember that personal prejudice can enter into things to a very large extent. For this reason the best test material is not music but such things as pure sine waves (for distortion) and applause, or better still white and pink noise (for transient response).

Regarding the use of pink noise, which incidentally is only white noise attenuated

by 3dB per octave with increasing frequency, the following incident happened to the author. A pink noise generator had been built and was being tested with a speaker system. A most noticeable hum was produced and all attempts to find the source in the generator failed. It was finally discovered that the hum was not present in the noise, but was the fundamental resonance present in the speaker system. This speaker (which was of the unlagged reflex type) had previously been used in music tests, and several people had commented on the good performance, particularly in the bass region.

If the cabinet size is felt to be rather too large, then it is possible to scale all the dimensions given according to the diameter of the bass driver being used. This will result in a poorer bass performance and is not advised, but a very creditable performance is possible using an 8in driver unit and scaling all the dimensions by four fifths. This factor results from the recommended bass driver having the same effective cone area as a normal 10in unit of circular construction.

In conclusion it must be emphasized that only the system as described is in any way guaranteed. Readers can experiment, of course, but must be prepared to solve their own problems.

## Sixty Years Ago

May 1912. The Marconigraph carried a long article devoted to the loss of the Titanic and the part wireless played in the rescue of the survivors. The Titanic sailed on April 10th and on April 15th struck an iceberg. The distress call was answered by the Carpathia.

The wireless installation on board the Titanic probably represented the state of the art at the time and was described in the article as follows.

The wireless equipment of the Titanic was the most powerful possessed by any vessel of the mercantile marine. Its generating plant consisted of a 5-kW motor-generator set, yielding current at 300 volts 60 cycles. The motor of the set was fed at 110 volts d.c. from the ship's lighting circuit, normally supplied from steam-driven sets; while, in addition, an independent oil-engine set was installed on the top deck, and a battery of accumulators was

also provided as a stand-by. The alternator of the motor-generator set was connected to the primary of an air-core transformer, and the condenser consisted of oil-immersed glass plates. To eliminate as far as possible the spark-gap and its consequent resistance, which as is well known, is the principle cause of the damping of the waves in the transmitting circuit, the ordinary Marconi rotary disc discharger was used. This is driven off the shaft of the motor-generator. The guaranteed working range of the equipment was 250 miles under any atmospheric conditions, but actually communication could be kept up to about 400 miles, while at night the range was often increased up to about 2,000 miles. The aerial was supported by two masts, 200ft. high, stepped 600ft. apart, and had a mean height of 170ft. It was of the twin T type, and was used for the double purpose of transmitting and re-

ceiving. The earth connection was made by insulated cable to convenient points on the hull of the vessel.

'The receiver was the Marconi standard magnetic travelling band detector used in conjunction with their multiple tuner, providing for the reception of all waves between 100 and 2,500 metres. The multiple tuner was calibrated to permit of the instrument being set to any prearranged wave-length, and further to be provided with a change switch to permit of instantaneous change of the circuit from a highly syntonized tuned condition to an untuned condition (for stand-by) especially devised for picking up incoming signals of widely different wave-lengths. By reason of its robust nature the magnetic detector could be employed permanently connected to the transmitting aerial, thus dispensing with all mechanical change over switching arrangements.