

Current dumping—does it really work?

Theory and practice

by J. Vanderkooy and S. P. Lipshitz University of Waterloo, Ontario

This article endorses the soundness of the current dumping principle, though querying whether its should be called feedforward error correction in the feedbackloop. In several respects the distortion reduction appears due to a passive bridge balance. It shows that dumper β -variation results in distortion, fortunately very low, which cannot be balanced out in present circuits. Readers are challenged to produce a circuit which nulls out such current distortion as well.

Measurements, in part 2, show that the amplifier performs very well, and analyses of the distortion oscillograms and wave analyser measurements show that, qualitatively, much of this data can be understood. We both heartily agree that the current dumping principle as embodied in the QUAD 405 amplifier has significantly advanced the state of the art in class B power amplifier design.

A FLURRY OF EXCITEMENT and controversy has occurred since the article on the current dumping amplifier by P. J. Walker¹. A class B audio amplifier capable of low crossover distortion, with no quiescent current, seems too good to be true! We have followed the letters to the editor with great interest, and noted that the situation seems to be a stalemate as regards the conventional feed-back versus feed-forward argument. Each of us has changed his mind regarding the operation of the amplifier several times. It was in this framework that we decided a more careful analysis was necessary. We present first a view of the theory as we see it, and later on deal with some corroboration

rating measurement made on a QUAD 405 amplifier.

Early letters have been adequately handled by Mr Walker², and we feel there is value in the equivalent circuit of Peter Baxandall³. But we fail to see how the independence of output impedance under two limiting conditions (dumpers on with infinite mutual conductance, off with zero gain) can imply distortionless behaviour.

There seems to be an advantage in the circuit, but it is precisely in the region of output transistor turn-on that such arguments are inapplicable. Accordingly, we were sceptical of the results, not having really taken the pains to work out all the details presented in Mr Walker's article and the letters. Referring to Fig. (d) of Mr Baxandall's letter, we were led to conclude that the distortion voltage created by the dumpers must somehow find its way out of the otherwise linear components. Mr Olsson's letter³ also requires an answer.

Simplified analysis

An illuminating but incomplete analysis of the amplifier is possible. The effect of the dumpers can be looked on as a distortion voltage applied between the input and output of the dumper stage. In Fig. 1 assume for now that A has zero output impedance and has infinite gain (both conditions are related later), Labelling v_1, v_2, e_0, v_s, i_3 and i_4 as in Fig. 1

$$\frac{v_1}{Z_1} + \frac{v_2}{Z_2} + \frac{v_s}{R_s} = 0$$

As a result of the widespread advertising campaign for the QUAD 405, we have heard it referred to as the "currently dumped amplifier". (We trust that the Acoustical Manufacturing Co. will forgive us for this levity.)

and summing i_3 and i_4 for the total current

$$\frac{v_2 - e_0}{Z_3} + \frac{v_1 - e_0}{Z_4} = \frac{e_0}{Z_L}$$

These two equations are easily solved for e_0 in terms of v_s and either one of v_1 or v_2 (we give both for didactic reasons):

$$e_0 \left(\frac{1}{Z_L} + \frac{1}{Z_3} + \frac{1}{Z_4} \right) = - \frac{Z_2}{Z_3 R_s} v_s + v_1 \left(\frac{1}{Z_4} - \frac{Z_2}{Z_1 Z_3} \right),$$

or

$$e_0 \left(\frac{1}{Z_L} + \frac{1}{Z_3} + \frac{1}{Z_4} \right) = - \frac{Z_1}{Z_4 R_s} v_s + v_2 \left(\frac{1}{Z_3} - \frac{Z_1}{Z_2 Z_4} \right). \quad (1)$$

Either equation shows that e_0 will not depend on v_1 or v_2 , which have distortion, if $Z_1 Z_3 = Z_2 Z_4$, just the Walker balance condition. Under this condition the output e_0 depends only on v_s (with the same coefficient now) and not on the distortion voltage $v = v_2 - v_1$.

If the gain A is made finite, a balance condition will still follow (messy algebra) as long as the amplifier A has zero output impedance, so that the dumper input current can be ignored**. This has been discussed by Bennett and Walker².

Another slant to the simplified analysis is to consider the output of the class A amplifier to be a true current source, with infinite output impedance. Then the equivalent circuit can be redrawn as in Fig. 2, with the dumpers again approximated by a voltage source, which admittedly is not very realistic with the current source approximation.

The class A amplifier has been characterised by a transconductance G_m with the output connected to the point V_2 . To avoid getting dumper voltage distortion (v) into the output, any signal due to v at the inverting input of the class A amplifier should be zero. This requires $Z_1 Z_3 = Z_2 Z_4$ independent of the value of G_m , because the criterion is simply a passive balance of the bridge. It

For finite gain A, the dumper distortion v cannot be balanced to zero if the bridge is destroyed by shorting Z_4 . in the circuit of Fig.1 This fact also follows from our more general analysis below.

Fig. 1. Simplified equivalent circuit of the current dumping principle considering only dumper voltage distortion.

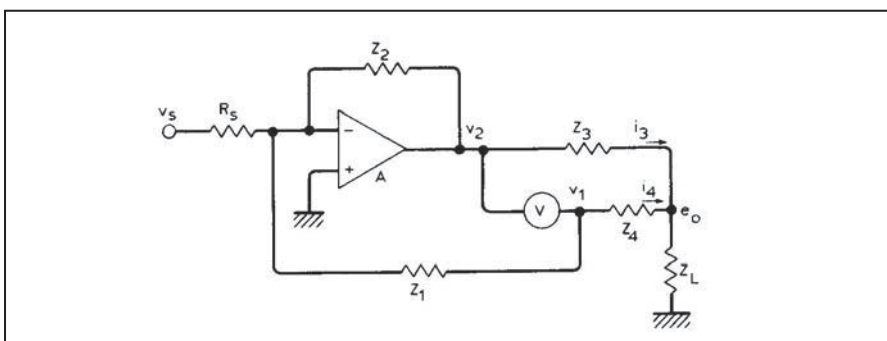

might be considered passive feedforward error correction in amplifier with judicious feedback applied.

Naturally the effect of the dumpers is to amplify current, and then such a simple analysis is not warranted. Passive balance is lost and a more general analysis is necessary to establish if a balance condition still exists.

Balance condition

If the balance condition $B = 0$ can be achieved (see boxed item) the output e_o will contain no dumper distortion contributions. The condition $B = 0$ is the counterpart of the Walker balance condition $Z_1 Z_3 = Z_2 Z_4$ which followed from setting the coefficient of v_2 equal to zero in our earlier equation (1). This condition is analysed next in some detail as it really contains all the information we have been seeking.

Firstly, returning to a remark made earlier ** suppose that Z_4 is omitted (i.e. short-circuited), thus destroying the bridge. Solving the equation $B = 0$ for G_m in this case $G_m =$

$$-\frac{\beta \{ (Z_1 + Z_2 + Z_3)R_s + Z_1(Z_2 + Z_3) \} + Z_1 Z_3}{(\beta + 1)Z_1 Z_3 R_s}$$

which is negative δ . For d.c. stability, we must assume G_m to be positive so that the overall feedback around the amplifier be negative feedback. Thus no bridge balance condition is possible when $Z_4 = 0$.

Secondly the possibility of achieving bridge balance does exist in the general case. Rearranging the equation $B = 0$,

$$\frac{Z_2 Z_4 - Z_1 Z_3}{\beta \{ (Z_1 + Z_2 + Z_3 + Z_4)R_s + Z_1(Z_2 + Z_3) \} + (\beta + 1)G_m R_s + 1} = 0 \dots (3)$$

Provided $Z_2 Z_4 > Z_1 Z_3$ and assuming these impedances to be real for the moment, balance can be achieved for finite transconductance G_m as long as β can be assumed to be a constant. In fact, equation (3) gives the value of G_m re-

δ Unless explicitly stated otherwise, we assume that $Z_1, Z_2, Z_3,$ and Z_4 are real.

More detailed analysis

The QUAD 405 contains a class A amplifier which has a **current output**. Referring to Fig. 4 of Peter Walker's article¹, the collector of Tr_7 is the output of this amplifier. The resistor R_{30} is not a significant load as it is "bootstrapped away" by C_{10} . Other connections to this point are the dumper bases, Z_2 and Z_3 . Capacitors C_9 and C_{11} , presumably to prevent r.f. instability, are ignored. Hence in an improved modelling circuit we consider the class A amplifier to have a current output and a transconductance G_m from input (emitter of Tr_2) to output (collector of Tr_7). **Capacitor C_8 (Z_2) does not really connect to the same point as R_{20}/R_{21} (Z_1)** something about which more will be said later. Consider now the circuit shown in Fig. 3, ignoring Z_0 for the moment.

Dumper current gain is set at $\beta + 1$, but of course $\beta + 1$ will change from about 20 when Tr_9 conducts to about 2000 when Tr_8 and Tr_{10} conduct.

The defining equations and their meaning are all given below.

- Setting amplifier input current to zero:

$$\frac{v_s - v_i}{R_s} + \frac{v_2 - v_i}{Z_2} + \frac{v_1 - v_i}{Z_1} = 0$$

- Setting class A output current equal to $-G_m v_i$:

$$-G_m v_i = \frac{v_2 - v_i}{Z_2} + \frac{v_2 - e_o}{Z_3} + i_b$$

- If dumper output current is properly accounted for:

$$(\beta + 1)i_b = \frac{v_1 - e_o}{Z_4} + \frac{v_1 - v_i}{Z_1}$$

- Using the currents in Z_3 and Z_4 to calculate e_o :

$$\frac{v_2 - e_o}{Z_3} + \frac{v_1 e_o}{Z_4} = \frac{e_o}{Z_L}$$

Here there are six variables ($v_s, v_i, v_1, v_2, i_b, e_o$) and four equations, so three of our variables can

be eliminated. Choosing to calculate e_o as a function of only v_s and i_b and manipulating gives

$$\begin{aligned} & [(Z_1 + Z_2 + Z_3 + Z_4)(Z_L + R_s + Z_L R_s G_m) \\ & + (Z_1 + Z_4)(Z_2 + Z_3 + Z_3 R_s G_m)] e_o \\ & = [(\beta + 1) \{ (Z_1 + Z_2 + Z_3 + Z_4)R_s \\ & + Z_1(Z_2 + Z_3) - (Z_2 Z_4 - Z_1 Z_3)R_s G_m \} \\ & - \{ (Z_1 + Z_2 + Z_3 + Z_4)R_s \\ & + (Z_1 + Z_4)Z_2 \}] Z_L i_b \\ & + [(Z_1 + Z_2 + Z_3 + Z_4) \\ & - (Z_1 + Z_4)Z_2 G_m] Z_L v_s \end{aligned} \dots (2)$$

which we write as

$$A e_o = B Z_L i_b + C Z_L v_s$$

where the coefficients A, B and C are represented by the expressions in square brackets δ

These equations are all linear, and it is good to pause awhile to ponder whether the distortion has been properly considered. The voltage across the dumpers $v_2 - v_1$ will control i_b for the output $(\beta + 1)i_b$ in a complex way related to the turn-on curve of the dumpers. In choosing to eliminate v_1 and v_2 , the distortion must appear in our equations as a distorted i_b which is not a copy of e_o or v_s . We deliberately chose to eliminate v_1 and v_2 from our equations so that all the dumper distortion contributions to e_o occur in the single term $B Z_L i_b$. Now e_o can still be made rigorously proportional to v_s , if the large bracket B multiplying i_b can be set equal to zero for all signals. (The parameter β occurs only in the coefficient B in equation 2). The balance condition for the new equivalent circuit of Fig. 3 is thus $B = 0$.

δ This is essentially a d.c. analysis of the circuit, and as such will remain valid only for frequencies low enough that time delay effects through the class A amplifier and bridge components can be ignored.

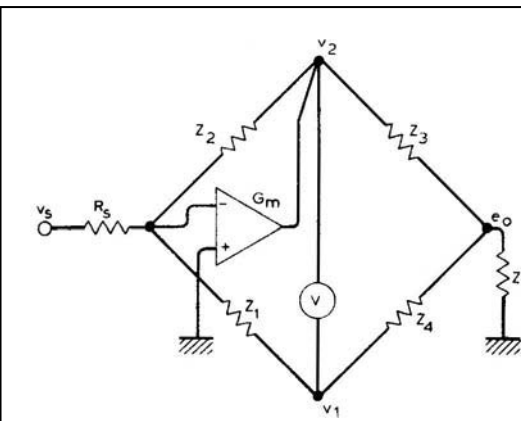

Fig. 2. Simplified equivalent circuit showing that passive bridge balance can remove dumper voltage distortion

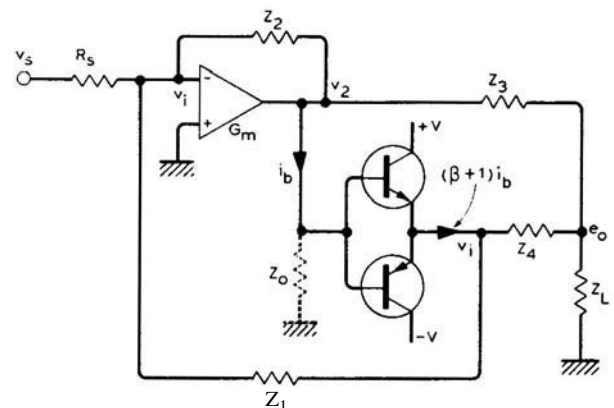

Fig. 3. Equivalent circuit for more complete analysis, see box.

quired for perfect bridge balance, and hence complete independence of the Output from dumper distortion. A vital requirement that this be completely achievable in practice is that β be constant. (The extent to which non-constancy of β contributes to the presence of dumper distortion in the output is examined later.)

Thirdly, from equation 3), if G_m tends to infinity then the balance condition reduces to precisely the Walker condition $Z_2 Z_4 = Z_1 Z_3$ which appeared in the simple analysis of Fig. 1. So for large transconductance in the class A stage, the balance condition is precisely that obtained before. Moreover, Z_2 and Z_4 can be respectively capacitive and inductive without affecting our argument

Fourthly, we can now answer the claims by Olsson and others that the (non-linear) dumper input current i_b prevents the attainment of perfect bridge balance in the case of finite G_m . The analysis of Fig. 3 shows that no matter how non-linear i_b may be, if β is constant perfect balance can be achieved with finite G_m . Lest Fig. 3 is thought unrealistic, in that in practice a perfect current source is not available for the class A amplifier, we have made a more complete analysis. Taking into account the shunting effect of a load Z_o shown broken in Fig. 3 across this stage in any practical case, and we find that it has absolutely no effect upon the balance condition $B=0$. The only effect of Z_o in equation (2) is to add further terms to the coefficient A of e_o , but it does not change the other coefficients. As a perfect current generator shunted by Z_o is equivalent to a voltage source with a finite output impedance, by including Z_o in Fig. 3 we have shown that balance is achievable even with an imperfect class A stage, provided β is constant and assuming Z_2 and Z_4 to be real.

Next, we must answer the question which we have thus far begged: To what extent will variations of β in the dumper stage (which certainly are present to considerable extent in the QUAD 405 circuit, and at least to a certain extent in any realizable class B output stage) contribute to dumper distortion appearing in e_o through the incomplete cancellation of the term $BZ_L i_b$? From the balance equation (3) provided β does not fall to low and provided G_m is large, the effect of changing β will be small.

To quantify this conclusion, return to equation (2). Assume that β varies from say β_{min} to β_{max} as the dumpers operate. The dumper output current βi_b , denoted by I_D can be assumed to be constant to a first order approximation and independent of β in the operation of the circuit. If Δe_o represents the peak-to-peak distortion in the output signal e_o due to changing β in the dumpers, then

This formula can be further approximated assuming (as in the QUAD 405) that the bulk of the load current furnished by the dumpers, so that $I_D = e_o / Z_L$, and that Z_2 and G_m dominates the terms on the right-hand side. Then

$$\frac{\Delta e_o}{e_o} \approx \frac{(Z_1 + R_s) \left(\frac{1}{\beta_{min} + 1} - \frac{1}{\beta_{max} + 1} \right)}{G_m Z_L R_s} \dots(4)$$

This distortion has the shape of a half-wave-rectified sine wave. That due to changing dumper current gain can be reduced to insignificance by making β_{min} and G_m adequately large. This component of distortion then is being reduced by conventional feedback on account of the appearance of G_m in the denominator of equation (4). This distortion percentage is independent of the output signal provided it is large enough to cause both dumpers to operate and is also frequency-independent. We comment later on the possibility of removing such distortion entirely.

In the QUAD 405, where approximately Z_1 is 500 Ω , R_s 180 Ω (R_{16} in the circuit diagram, Fig. 4 of ref. 1) Z_L 8 Ω , β_{min} 20, and G_m 50,000A/V, the distortion expected due to changing β is of the order of 10 μ Vpeak or about 132dB below full output and hence negligible.

Further interesting conclusions can be drawn from equation 2. For instance, it can be shown rigorously that for large G_m , the output impedance of the amplifier is that of Z_3 and Z_4 in parallel. The voltage gain of the amplifier equivalent circuit e_o/v_s can also be shown to be approximately $-R_1/R_s$.

More interesting, perhaps, is an estimate of the effect of bridge unbalance on the output distortion. Returning to equation (2) to calculate the effect, Δe_o , on e_o of a change ΔZ_i of any one of the bridge impedances Z_1, Z_2, Z_3 or Z_4 (assuming Z_2, G_m large), and considering that the dumper notch distortion ($\Delta V \approx 1.5V$) results in a peak-to-peak fluctuation ΔI_D in I_D of approximately $1.5/R_3$ amps then

$$\Delta e_o \approx \frac{1.5Z_1}{Z_2} \cdot \frac{\Delta Z_1}{Z_1}$$

The dumper distortion voltage approximates a square wave of amplitude 1.5 volts, whose transition time is determined by the signal frequency and amplitude, the dumpers and Z_4 . Our formula for bridge error shows that if $Z_2 = 1/j\omega C$, then the distortion seen from bridge unbalance will be the time derivative of this, which would appear as sharp spikes whose amplitude depends directly on the speed of the transition

Further thoughts

Recapitulating on the operation and analysis of the current dumping amplifier, the dumpers produce a distortion voltage which is completely removed by a balance condition which approximates to $Z_1 Z_3 = Z_2 Z_4$ and which becomes progressively less dependent on the gain G_m of the class A amplifier as it is made large. A second kind of distortion is the asymmetry of the dumper current gain, and any non-linearity of this gain with signal. This current distortion cannot be balanced out, and its effects vary as $1/G_m$, so they are reduced by conventional feedback. In the QUAD 405 amplifier this distortion appears to be low but perhaps not negligible.

In electronics, the concept of duality allows a voltage source to be transformed to a current source and vice versa. We feel it is possible that a bridge configuration exists such that the current distortion can be nulled as well as the voltage distortion. It may be possible to superimpose the two bridges with one class A amplifier. We have devised several theoretical methods for removing current distortion entirely, maintaining the normal bridge components, by applying positive current feedback to the class A amplifier to give it zero output impedance. The value of β then disappears from the analysis.

However, the amount of feedback required depends on G_m . We feel a better solution is possible and challenge the readers of this journal to produce one.

Results of measurements will appear in part 2.

References

1. Walker P. J. Current dumping audio amplifier. *Wireless World* vol81, December 1975, pp. 560-562.
 2. Letters to the editor. *Wireless World* vol. 82, April 1976, pp. 54-55.
 3. Letters to the editor. *Wireless World* vol. 82, July 1976, pp. 60-62.
- keith@snook.eu

$$\Delta e_o \approx \frac{\left\{ (Z_1 + Z_2 + Z_3 + Z_4)R_s + (Z_1 + Z_4)Z_2 \right\} \left(\frac{1}{\beta_{min} + 1} - \frac{1}{\beta_{max} + 1} \right) Z_L I_D}{(Z_1 + Z_2 + Z_3 + Z_4)(Z_L + R_s + Z_L R_s G_m) + (Z_1 + Z_4)(Z_2 + Z_3 + Z_3 R_s G_m)}$$

Current dumping — does it really work?

2—Measurements

by J. Vanderkooy and S. P. Lipshitz University of Waterloo, Ontario

This article (part 1 appeared in the June issue) shows theoretically that the current dumping principle is quite sound. Whether it should be called feedforward error correction in the feedback loop is perhaps still open to debate. In several respects the distortion reduction appears due to a passive bridge balance. Dumper beta variation results in distortion, fortunately very low, which cannot be balanced out in present circuits, and readers are challenged to produce a circuit which nulls out such current distortion as well.

Measurements show that the amplifier performs very well, and analyses of the distortion oscillograms and wave analyser measurements show that, qualitatively, much of this data can be understood. We both heartily agree that the current dumping principle as embodied in the Quad 405 amplifier has significantly advanced the state of the art in class B power amplifier design.

IN ATTEMPTING TO MAKE distortion measurements on a QUAD 405 amplifier (SNI861), we found no oscillator with sufficiently low distortion was available to us. After a number of modifications, we employed a Heathkit IG-18 whose distortion finally measured out at <0.002% at audio frequencies around 1kHz. We found that the Hewlett-Packard 302 wave analyzer, when fed a full scale signal, produced internal distortions or intermodulation with internal noise such that distortion components lower than 0.005% were difficult to measure. Accordingly, we employed a switchable passive twin-tee notch filter to remove the fundamental to the wave analyzer in all our measurements.

Correction factors for the twin-tee filter were applied to the measured harmonics to give total harmonic distortion, which excludes the wide-band amplifier noise. While making measurements we found it very interesting to observe with an oscilloscope the twin-tee filter output, having the fundamental largely removed. The noise of the QUAD 405 is considerably higher than that of the QUAD 303 power amplifier, probably because of the integrated operational amplifier used in the 405. This noise interfered with the oscilloscope display and in several instances we found it

useful to place a capacitor across C6 of the amplifier circuit.

The most important point we wished to check was the operation of the distortion nulling bridge. We did this firstly by observing the distortion signal with the amplifier as supplied, and also with Z_4 (the 3 μ H inductor L_2) shorted. This is easy to do and not very upsetting to the amplifier's stability. Fig.4 shows a photograph of the

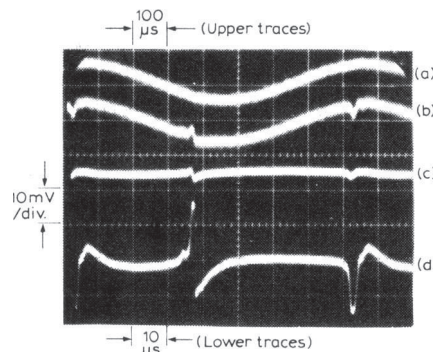

Fig. 4. Oscilloscope illustrating residual distortion voltage at output of twin-tee filter at 1.32kHz (top two traces) and 13.2kHz (bottom two). In each case the lower trace shows the effect of shorting the inductor Z_4 (Output 1V r.m.s. into 10 Ω .)

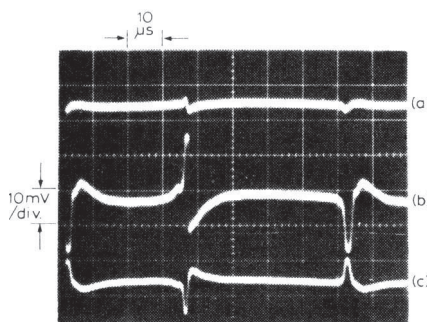

Fig. 5. Oscilloscope illustrating the effect of unbalancing the bridge in both directions. Upper trace is with amplifier as supplied; middle trace with bridge unbalanced in one direction (Z_4 shorted), and lower trace with bridge unbalanced in opposite direction (Z_1 shunted). All at 13.2kHz, 1V r.m.s. output across 10 Ω .

distortion output after the twin-tee for four cases. Starting from the top, (a) is the resultant at 1.32kHz for 1Vrms output into a 10-ohm load, amplifier as supplied; (b) is the same with Z_4 shorted; (c) the same as (a) but with signal frequency of 13.2kHz; and (d) the same as (c) but with Z_4 shorted. Notice that the twin-tee allows some fundamental residue to remain in (a) and (b). The traces clearly show the beneficial effect of the bridge element Z_4 , especially at high frequencies, as one might expect. They also clearly answer Mr Bennett's objections (ref. 2, part 1): vastly larger amounts of negative feedback would be required to achieve as low a distortion as can be achieved by inserting Z_4 and balancing the bridge.

The fact that the amplitude of the notch distortion in Fig. 4 increases visibly with frequency and consists in large measure of sharp spikes, suggests very strongly that this remaining distortion is due to residual bridge unbalance. This is as predicted by our analysis, and is further reinforced by Fig. 6 (see later). The spikes are roughly constant for output levels from 1.5 to 10Vrms; to understand this feature even qualitatively requires a more complete treatment of crossover distortion than we can give here.

It is worth remarking that for outputs less than about 200mVrms the notches disappear completely, as the dumpers remain off and the amplifier operates in pure class A. Hence at very low power, crossover distortion is totally absent. As the output signal amplitude is increased beyond about 10Vrms (at 13.2kHz), the peak-to-peak notch amplitude rises, until at 25Vrms output it has risen by a factor of four from 5 to 20mV pk-pk. This strongly suggests that this effect is due to β variation in the dumpers, as our theory predicts that this contribution should rise in amplitude with output level. We have not, however, been able to correctly predict the magnitude of this effect from our equations. It may well be that the slow dumper transistors have a region near crossover where $\beta \approx 0$ or $\beta < 0$ after a quick turnoff.

Finally, each spike in trace (d) in Fig. 4 is in fact composed of two spikes of vastly different amplitudes. It would appear that the smaller spike is caused by the switching of the upper (single)

dumper, while the larger spike is contributed by the lower dumper pair (with its higher speed).

Fig. 5 shows that the amplifier as supplied has a bridge roughly in balance. All traces are at 13.2kHz with 1Vrms out across 10 ohms; horizontal scale 10μs/division, vertical scale 10mV/division; twin-tee in circuit. The upper trace shows the amplifier as supplied. The middle trace shows the effect of shorting Z_4 , the inductor L_2 . This unbalances the bridge in one direction. The lower trace is produced by restoring Z_4 and resistively shunting Z_1 (the 500Ω resistor) to unbalance the bridge in the opposite direction. Comparing traces, the bridge as supplied is reasonably well balanced, perhaps within 10%, which is to be expected with four 5% components.

The remaining glitches in the distortion waveform suggest that the bridge is not perfectly balanced, or that some other distortion mechanism such as dumper β variation may be occurring. Fig. 6 shows the results of several attempts to achieve better bridge balance. The signal frequency is 13.2kHz, horizontal scale 10μs/division, vertical scale 5mV/division. The upper trace shows the twin-tee output for the amplifier as supplied. The middle trace shows the best balance that can be achieved by shunting Z_1 (the 500Ω resistor) with a resistance which for our amplifier was about 5kΩ. The lower trace is the result when Z_1 is shunted by two resistors in series, with their junction going via a 100μH inductor to ground.

This was an attempt to balance the bridge, taking into account the effect of C_9 (330pF), R_{19} (3.3kΩ) and the collector capacitance of Tr_3 . Although one may think that such effects should be negligible because Tr_3 has a β of say 100, any collector current due to capacitance goes through an active base and is

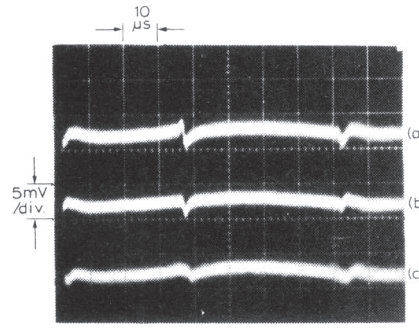

Fig. 6. Oscillogram illustrating attempts at achieving perfect bridge balance. Upper trace is twin-tee output of amplifier as supplied, middle trace shows best balance achieved by resistively shunting Z_1 and lower trace is best balance with complex shunt. All at 13.2kHz, 1V r.m.s across 10Ω.

multiplied by β. (A recent Quad 405 circuit shows C_9 and C_{11} replaced by a single capacitor, a configuration we have not analysed). The slightly better appearance of the lower trace indicates some success on our part, but the problem is complex and subtle. There may also be an effect due to the separation of Z_1 and Z_2 these being fed back to opposite ends of Tr_2 the input transistor. The distortion signals fed back through Z_1 and Z_2 will not be quite right, due to the different impedances at opposite ends of Tr_2 . We believe that this effect can be seen in Figs 4 and 5 with Z_4 shorted. The large spikes are followed by an exponentially decreasing waveform with a time constant of about 5μs. If one estimates the impedance at the collector of Tr_2 (the input transistor, triple input, and the current source Tr_1) at about 50kΩ, the 120pF capacitor (Z_1) gives a time constant with this impedance of 6μs. No other time constant seems near to this value, indicating that

an effective bridge unbalance may have resulted from the separation of Z_1 and Z_2 . The only other possible cause could be a slow dumper turnoff.

Several other features tend to influence the bridge and the dumper β variation. Although C_{10} bootstraps R_{30} (560Ω), this resistor now forms a shunt across the dumper stage from bases to emitters. This will influence the effective β for the dumpers in the crossover region (there will be a small current region for which $β < 0$, using a d.c. analysis). As the dumpers are slow, an a.c. analysis is almost impossible, and they may well be the cause of much of the residual distortion. Because of the bootstrap capacitor C_{10} , R_{31} (also 560Ω) now forms a load to an a.c. ground (the negative rail), which tends to unbalance the bridge. Our calculations show that this has an almost negligible effect at audio frequencies, because the relevant ratio turns out to be the conductance of R_{31} relative to that of Z_4 . (The presence of the loading effect of R_{31} slightly changes the bridge balance condition $B = 0$ by, in effect, modifying β very slightly. The possibility of achieving a balance is not affected.)

Another source of distortion in the QUAD 405 amplifier is the non-linearity in the modulation of β of Tr_2 (the input transistor following the operational amplifier) due to collector voltage variations. This transistor has a collector-to-emitter voltage which is modulated by 180/680ths of the output voltage, due to the feedback resistors. Suppose that the non-linearity of the collector current with voltage variation is 1% of the quiescent current of about 6mA. Using a simple diode model for Tr_2 we can easily show that such non-linearity of β with voltage results in a distortion of around 0.001% at full output level. Such distortion is mainly second harmonic and will become negligible at low power levels.

Fundamental		Harmonic distortion measurements with Quad 405 bridge balanced as accurately as possible																
		nth order harmonic distortion [%]																
		2	3	4	5	6	7	8	9	10	11	12	13	14	15	16	17	t.h.d. [%]
1.32 kHz	signal generator	.0011	.0004	N	N	N	N	N	N	N	.0001	N	N	N	N	N	N	.0012
	Quad 405. 1V _{rms} . best resistive balance	.0051	.0072	.0058	N	.0042	N	.0024	.002	N	.0021	N	N	N	N	N	N	.012
	Quad 405. 1V _{rms} . Z_4 shorted	.017	.016	.022	.0049	.021	.005	.016	.012	.0089	.014	.0021	.013	.0031	.01	.0062	.0072	.051
	Quad 405. 10V _{rms} . best resistive balance	.004	.0005	.0007	.0007	.0004	.0005	N	.0004	N	.0003	N	.0003	N	N	N	N	.0042
	Quad 405. 10V _{rms} . Z_4 shorted	.0046	.0014	.001	.0023	.0009	.0023	.0009	.0022	.0009	.0021	.001	.002	.0011	.002	.0011	.002	.0079
	signal generator	.0081	.0004	N														.0081
13.2 kHz	Quad 405. 1V _{rms} . best resistive balance	.012	.0063	.0039														.014
	Quad 405. 1V _{rms} . Z_4 shorted	.14	.14	.18														.27
	Quad 405. 10V _{rms} . best resistive balance	.011	.0034	.0023														.012
	Quad 405. 10V _{rms} . Z_4 shorted	.017	.027	.0015														.032
	signal generator																	
	Quad 405. 10V _{rms} . best resistive balance																	

N denotes Signal below noise: wave analyzer bandwidth 2Hz

To gain some insight into the magnitude of the remaining distortion components in the QUAD 405, it may be instructive to quote some figures. The table gives harmonic distortion measurements (of harmonics up to 50kHz) made as outlined earlier, with the QUAD 405 bridge resistively balanced as accurately as possible, as in, Fig.6, trace(b).

Clearly, the low-order harmonics expected, the measured residuals are of a very low amplitude indeed, and are frequently barely above the residual noise. Particularly impressive is the absence of measurable high-order harmonics, even at low powers. The enormously beneficial effect of Z_4 , already evident from the oscillograms, is again emphasised by these numbers. Much of the residual second and third harmonic distortion may be due to the class A stage, as this stage sets a limit on the ultimate performance of the whole amplifier. The contribution due to the input operational amplifier (which is outside the overall a.c. feedback loop) should also not be ignored.

About part 1*. Inconnection with our reference to Peter Baxandall's letter, page 38, Mr Baxandall has recently justified his approach quite clearly to us. We hope he will expand his elegant argument in his own series of articles. The second term in the laste quation of the middle column on page 39 should have a minus sign between v_I and e_O . word relaxed should have been used at the foot of column two, page 38, instead of "related."

** Script originally received October 1976.*

Additional reading

Quadi-complimentary, Elektor 8, December 1975, pp. 1220-2.

Quadi-complimentary complemented. Elektor 21, January 1977, pp. 1-39.

Letters to the editor, *WirelessWorld* vol.82, November 1976, pp. 52 / 3.

Letters to the editor, *WirelessWorld* vol.83, April 1977, p. 76.

Letters to the editor, *WirelessWorld* vol.83, June 1977, p. 49. keith@snookeu

Having a keen interest in electronics and audio, **John Vanderkooy** has contributed a number of articles in these fields. He is an assistant professor in the Department of Physics at the University of Waterloo, having previously spent two years on post-doctoral research at the University of Cambridge. John graduated from McMaster University, Hamilton, Ontario with a B.Eng. degree in engineering physics in 1963 and a Ph.D. in physics four years later.

With a long interest in audio and electronics, **Stanley Lipshitz** has recently begun investigating some of the mathematical problems associated therewith. He's an assistant professor in the Department of Applied Mathematics at the University of Waterloo. Before that he obtained his first degree in mathematics, applied mathematics and physics from the University of Natal, Durban, in 1964, an M.Sc. degree in applied mathematics from the University of South Africa, Pretoria, and the Ph.D. degree in mathematics from the University of the Witwatersrand, Johannesburg in 1970