

# Current dumping audio amplifier

Output power transistors' non-linearity does not appear in amplifier transfer characteristic

by P. J. Walker

Acoustical Manufacturing Co. Ltd.

If Harold Black did not actually invent negative feedback, he was certainly the first to show a comprehensive understanding of the subject in his famous patent of 1939. Nine years earlier he took out a patent on feed forward error correction<sup>1</sup>. Relatively small variations on this nearly 50 year old concept have led to the development of a new type of audio output circuit with attractive properties. The circuit was the subject of a paper presented to the 50th convention of the A.E.S. by M. P. Albinson and the writer earlier this year.

An audio power amplifier is required to produce an output signal that differs from the input signal in magnitude only. It must therefore have occurred to every circuit designer that it should be a simple matter to take a portion of the output, compare it with the input to derive an error signal. It is then only necessary to amplify this error signal and add it to the output in the correct amplitude and phase to cancel completely the distortion of the primary amplifier. Of course, one is left with distortion of the error amplifier but being of very low power this can be made negligibly small without much difficulty.

There is a special appeal in error forward error correction for transistor power circuits. Because of thermal limitations, the output transistors in the majority of audio amplifiers operate in

class B, in which alternate output transistors handle the negative and positive signal excursions. The output transistors are carefully biased to obtain a reasonably smooth transition from one to the other. If the bias is insufficient there will be a discontinuity in the transfer characteristic. If the bias is too great, there will be a region of overlap when the mutual conductance will be doubled. The curvature of the characteristic near cut-off precludes there being a perfect bias condition and this is further aggravated by the fact that the junction temperature and hence the bias is a varying factor depending upon both the long term and immediate past history of the programme dynamics. A compromise is

selected and overall feedback is applied to obtain an acceptably linear characteristic. Excellent amplifiers have been produced along these lines. Nevertheless, whereas feedback reduces distortion to a small and no doubt negligible amount, feed-forward carries the promise of reducing to zero the distortion of that part of the amplifier over which it is applied. If this is the class B stage, then not only does the distortion itself disappear but all the paraphernalia of quiescent current adjustment and thermal tracking disappears with it.

Feed-forward has only really flourished in areas where stability problems prohibit the use of feedback<sup>2</sup>. In the field of domestic audio amplifiers, it has failed to fire the imagination of all but a few<sup>3</sup>; presumably due to the extra complications and the undoubted practical problems of adding the error channel to the main 'stiff' output in an elegant manner.

If feed-forward is applied within the loop of a feedback amplifier, its stability advantage is necessarily forfeit. Nevertheless, in return, the need for a separate error amplifier can disappear and mutual loading problems disappear with it. A circuit developed on these lines carries an error component bypassing the main output transistors and so largely releasing them of linearity requirements. This technique has become known as 'current dumping' since this is descriptive of the rather mundane functions they are called upon to perform.

The basis of the new approach is shown in Fig. 1. Amplifier A is a small class A amplifier capable of providing the total required output voltage swing but with limited output current capability.  $Tr_1$  and  $Tr_2$  are current dumping transistors which supply the major part of the load current.

Fig. 1. Basic circuit parameters.

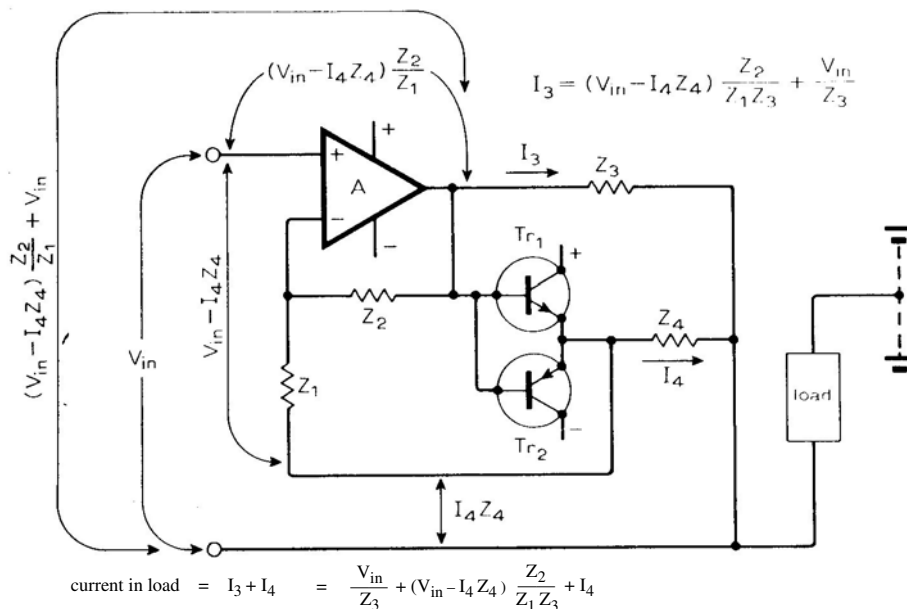

It will help in visualising the operation if the impedances are assumed to be resistors of values  $Z_1 = 1k \text{ ohm}$ ;  $Z_2 = 100 \text{ ohm}$ ;  $Z_3 = 100 \text{ ohm}$ ; and  $Z_4 = 1 \text{ ohm}$ . In the interest of simplicity we have assumed  $Z_4$  to be negligibly small compared to  $Z_1$ , and for the time being we will assume that the voltage output of amplifier A is completely defined by the external impedances.

With  $Tr_1$  and  $Tr_2$  turned off, amplifier A will deliver current to the load via  $Z_3$ . The current with the values suggested will be 1.01 amps/volt because the second term in the brackets is zero (no  $I_4$  current from the dumpers). When half a volt or thereabouts appears across  $Z_3$  one or other of the dumpers  $Tr_1$  or  $Tr_2$  will begin to turn on and pass some current  $I_4$  into the load. We have selected resistor values such that  $Z_4 Z_2 / Z_1 Z_3$  is unity so that the second term in the expression for the  $I_3$  current is exactly equal and opposite to  $I_4$  (this second term is the feed-forward error correction component). Currents  $I_3$  and  $I_4$  add in the load so that no matter what the magnitude of  $I_4$  the overall mutual conductance remains constant. We can say that any distortion in  $Tr_1$  and  $Tr_2$  produces perturbations in the current  $I_4$  and since this causes the exactly equal and opposite perturbations in  $I_3$  no distortion appears in the load.

$Tr_1$  and  $Tr_2$  have only one function to perform and that is to dump current into the load sufficiently accurately and sufficiently fast to come to the rescue of the class A amplifier and prevent it from overloading. If this is achieved then the class A amplifier, although it may have considerable gymnastics to perform, will be in complete control of the load current at all times.

*Fig. 1* does not look like a practical hi-fi amplifier since its output is constant current and the input is floating relative to the power supply. Nevertheless it is obvious that if the input is returned to the other end of the load all the unique properties of *Fig. 1* will still apply though perhaps a little less simple to visualise. This done, we have an amplifier whose output source impedance is  $Z_4$  and  $Z_3$  in parallel.

Two further changes are desirable. A practical amplifier is required to have an internal impedance small compared to the load at audio frequencies and stability requires that the internal loop gain falls with frequency. Both these conditions are met by the use of an inductor for  $Z_4$ , a capacitor for  $Z_2$  and resistors for  $Z_1$  and  $Z_3$ . The requirement for zero distortion from the dumpers is that  $Z_4 Z_2 / Z_1 Z_3$  is unity at all frequencies of interest. This is achieved if  $L = RRC$ . *Fig. 2* shows the circuit with the modifications carried out. (In order to keep the system operating at all frequencies it is necessary for a resistor in series with the inductor to have a conjugate match with a parallel resistor across the capacitor. This has been omitted for simplicity.)

*Fig. 2* begins to look very familiar, in fact just like a conventional amplifier with the biasing removed and a small inductor added. Is this really all that is necessary to produce the perfect amplifier? The answer, of course, is no, not quite; the circuit is over-simplified. We have pushed all the problems back

into the class A stage and whilst the distortion would indeed be zero if the class A stage were perfect, this cannot be completely so in practice. We assumed in our analysis that amplifier A was completely controlled by the external impedances, that it had a perfect virtual earth at its input which implied perfect regulation at its output. The effect of departure from this ideal can be assessed by calculation from a deliberate unbalance of the four component bridge, whether this is due to tolerances of any of the components or to inadequate 'stiffness' at the output of amplifier A. With the values shown in *Fig. 2*, a 5% error in any component value will produce maximum intermodulation products of around  $5\mu\text{V}$  at 1kHz; maximum possible i.m. of 0.01%, the maximum absolute level of these components being some 140dB below full power. Although frequency dependent, it is clear that balance is by no means critical and standard tolerance fixed components can be used without adjusting facilities.

We have said that the dumpers have

*Fig. 2. Basic diagram of principal elements*

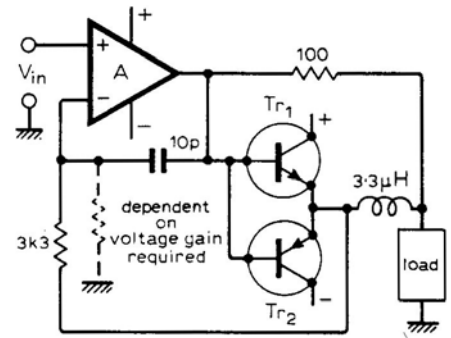

*Fig. 3. Simplified diagram showing Class a stage current dumpers and bridge components.*

CLASS A OUTPUT

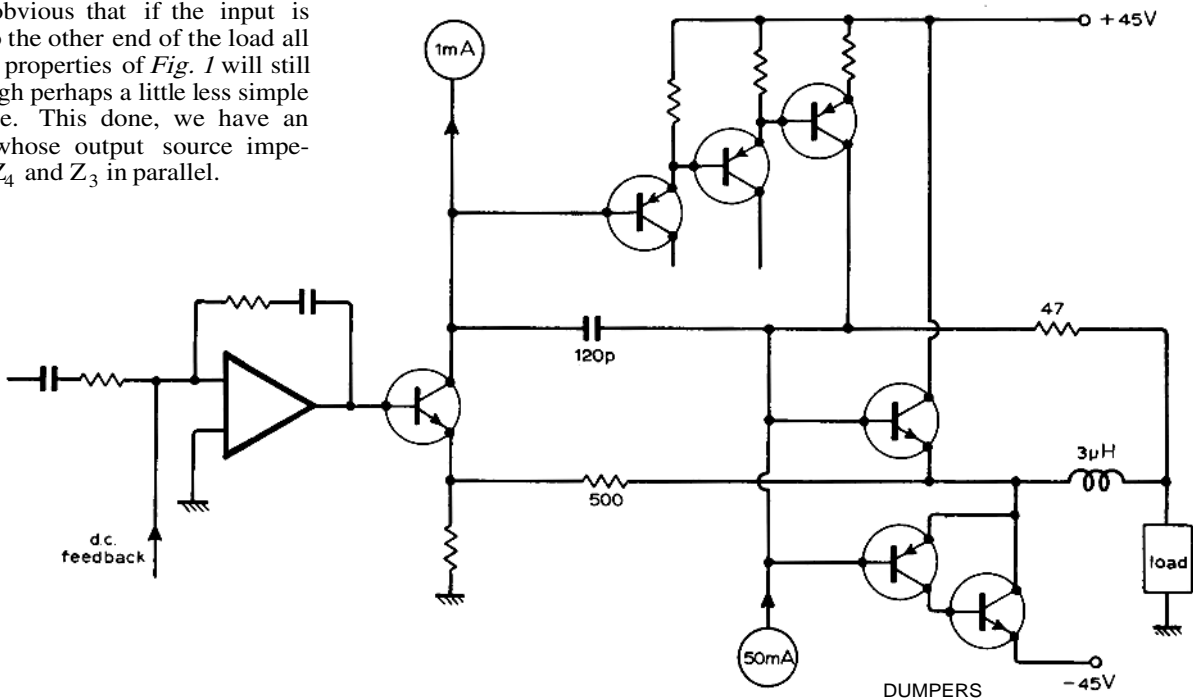

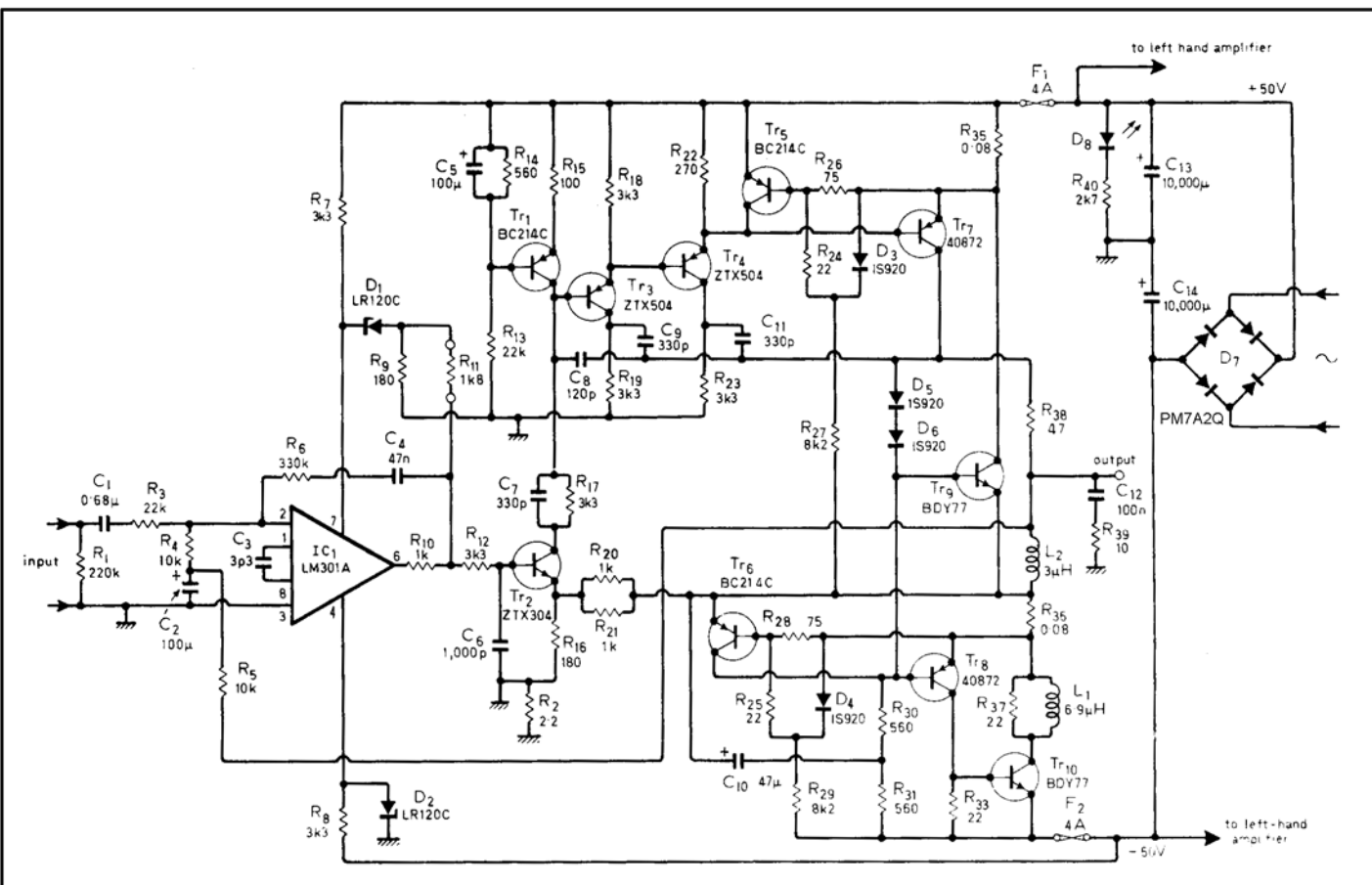
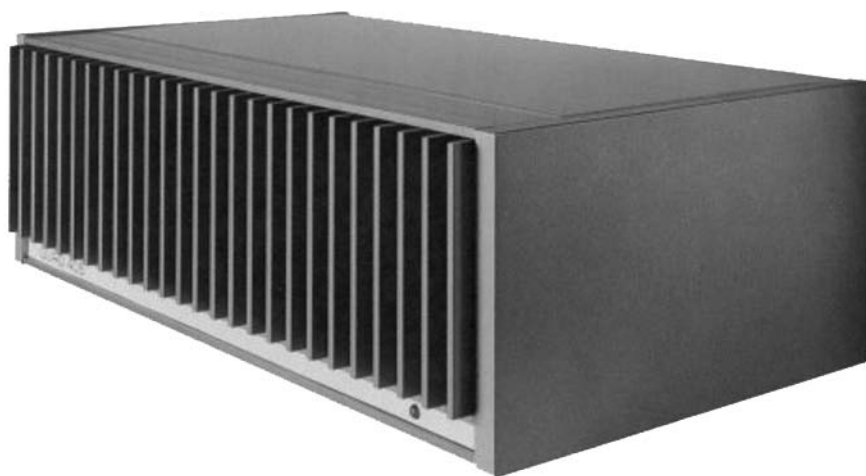

Fig. 4. Full circuit diagram. Resistor  $R_2$  is a protective connection provided to ensure earth continuity in the event that Tr2 and its associated component panel are disconnected from the common earth chassis.

Fig. 5. The Quad 405, a commercial realization of the circuit design.



practice that they will never fail to come to the rescue of the low powered amplifier to any programme. If, however, the criteria are thought to be response to step functions, square waves and other factors not relevant to programme, then of course faster dumpers must be used commensurate with the rise times involved.

Fig. 4 shows a commercial amplifier circuit (the QUAD 405) developed along these lines, Fig. 3 being a simplified diagram to indicate the relevant areas. The class A amplifier serves also as the driver for the top dumper. To counter this extra burden, the class A amplifier is a triple to give a very effective virtual earth. The mid frequency distortion of this amplifier measures about 0.005%, a region where slight component non-linearities etc. tend to deprive such measurements of any true meaning.

An extremely attractive factor of the technique is the complete absence of adjustments or alignment requirements and no thermal problems. Nothing to set up in manufacture and nothing to go out of adjustment during life. One may expect that after several years there will be far less variation, set to set, than is presently realised with most conventional circuits.

#### References

1. Black. USPat. 1,686,792. 9th October 1929.
2. Feed-forward error control. *Wireless World*, May 1972, p. 232.
3. Sandman, A. M. Reducing amplifier distortion. *Wireless World*, October 1974, pp. 367 - 371.