

QUAD II Power Amplifier

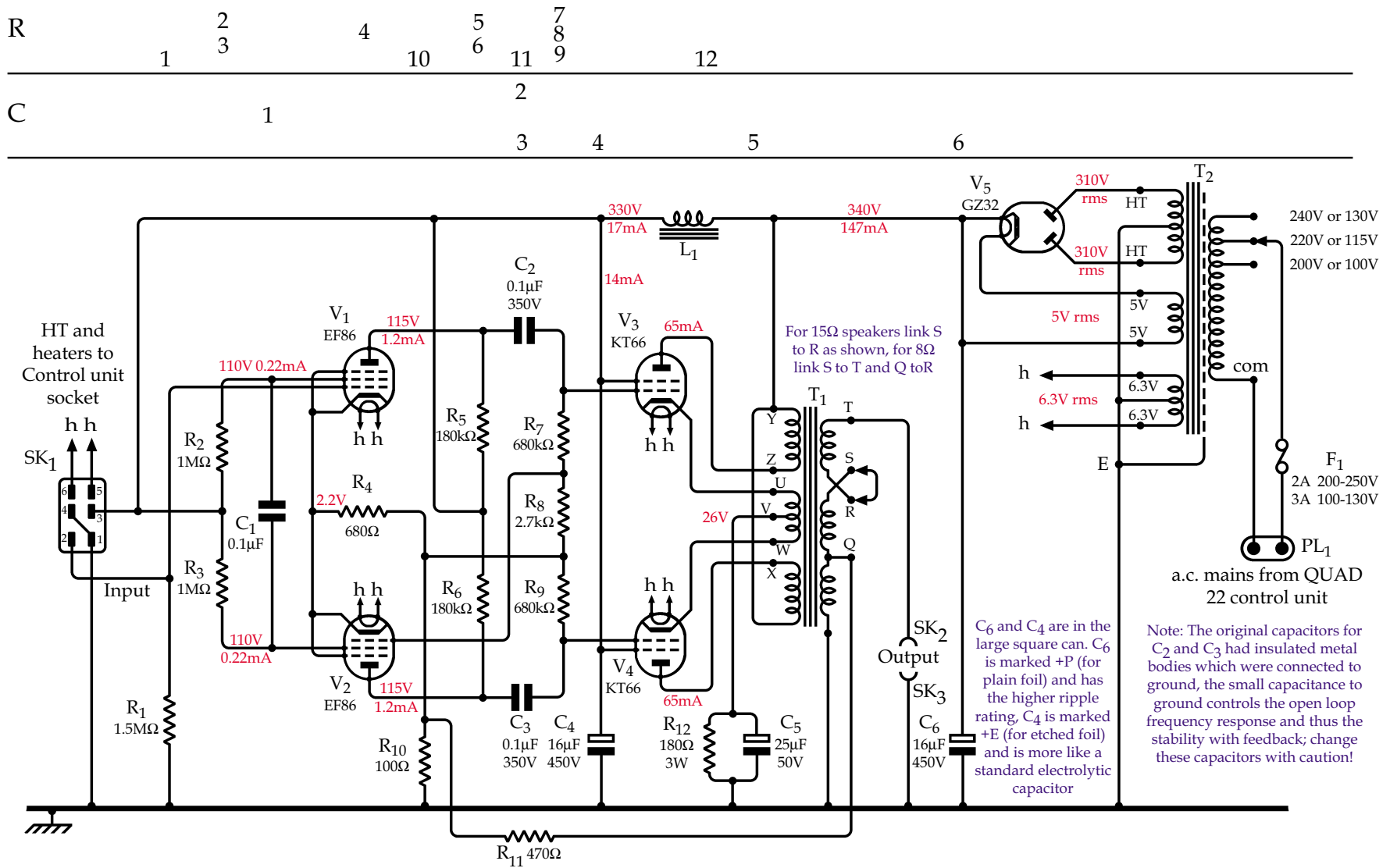

QUAD II Power Amplifier Schematic Drawing 11175 iss.1 Redrawn in original style by Keith Snook *d.c.~daylight ltd.* 1994 (new pdf version 2003)