

London Audio Fair

Review of a show attended by more than 70,000

In reporting on last year's Audio Fair we diagnosed an increasing interest in (and awareness of) the standards of good fidelity amongst visitors to the exhibition. A recent publication, *Audio in Transition**, predicts that the present boom will soon pass away leaving a steady growth rate of 20% per annum for the better quality products. (Does this really mean that the horrid systems associated with some 'household names' will vanish? One can only hope so!)

It is regrettable therefore that so many of the British manufacturers of well engineered audio equipment opted out of the Olympia show — although it must be noted that a few held satellite exhibitions in hotels off Kensington High Street — and it is a disappointment whatever the reason for non-attendance. One thing is for certain — it is possible to put on a first rate demonstration if the room is big enough. This was proved by Bang & Olufsen who made the most of the stand construction facilities offered, and created a highly civilized sound proof apartment conducive to relaxed listening. Of course there is a sound level limit for any size of room made of flexible panels, and our conclusion is that proper assessment of equipment is possible under Audio Fair conditions only if the sound level is tailored to room size. (Some loudspeaker demonstrations actually took place in square rooms!)

Once again *Wireless World* sponsored a lecture demonstration on each day. Tristram Cary fascinated many visitors with an audio visual demonstration of basic waveshapes, and showed how voltage controlled oscillators are used in modern synthesizers. Ralph West had assembled an enormous array of historical equipment all of which he miraculously got to work, spicing his discussion of the landmarks in audio with some very amusing asides. Arthur Bailey's discourse on loudspeakers included a demonstration of the new Ferrograph enclosure and the effect of cross-over component value tolerance on colouration. John Linsley Hood used AR3a speakers, a high-quality 70W per channel class B amplifier and a flashing-light meter to show how little signal power is required for average symphonic

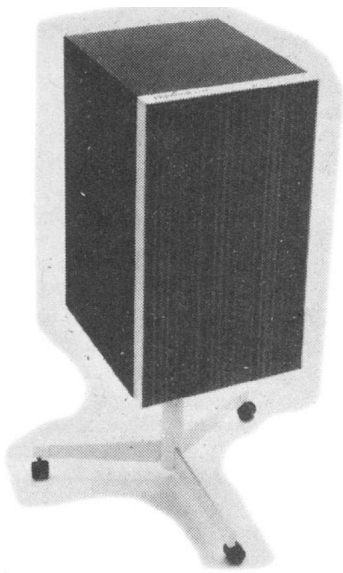

New-style bass reflex enclosure from Ferrograph.

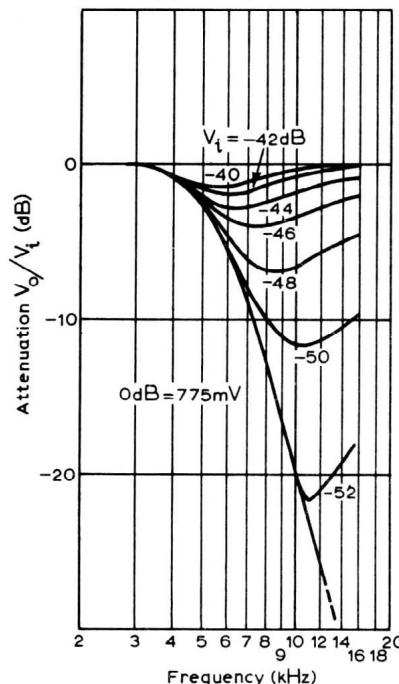

Fig. 1. Typical curves showing effect of playback-only dynamic noise reducing circuit. As input signal falls in level, circuit progressively attenuates tones above about 4kHz.

material and how much is required for piano reproduction. The final lecture demonstration was on horn loudspeakers, for which 'Toneburst' brought a pair of wooden horns based on the concrete design published in *Wireless World* in May 1970. Besides the clarity and frequency range of the system the solid stereo image attracted comment — the speakers were, of necessity, twenty six feet apart.

Noise reduction in cassette machines

To the list of current noise reduction techniques for cassette machines that we have mentioned recently — Dolby B, and systems used by JVC, National, Sanyo, Philips — we must add the Trio/Kenwood 'denoiser' (KF-6011). This is another playback-only system that attenuates high-frequency low-level signals depending on the signal level.

Just before the exhibition, Philips gave a demonstration of their dynamic noise limiter. They also demonstrated their DIN-standard cassette machine, N2510, which will be marketed at the end of 1972. Philips plan to market chromium dioxide tapes then, and their cassettes will have two extra holes so that when a cassette using the new tape is inserted, it automatically changes the bias and alters the equalization time constants from 120 and 3,180 to 70 and 3,180µs.

Returning to noise limiters, Philips admit theirs is not going to make cassette reproduction into 'hi-fi' reproduction. Given this qualification, it will be a welcome innovation for most cassette users, even though material containing low-level passages at high frequencies will be attenuated, the amount depending on level — see Fig.2. (When the h.f. or complete signal is zero there is full noise reduction of 10dB at 6kHz and 20dB at 10kHz.) The argument in all this is that musical instruments when played softly do not have a high harmonic content, and that they mostly have fundamentals below 4.5kHz — the frequency at which the noise circuit starts to take effect. (A point that Philips make is that the Dolby B system is not fully mono/stereo compatible — a stereo cassette processed using the Dolby B processor, is not truly mono

* Finnresearch Ltd, 30 Baker Street, London W.1. Price £18.

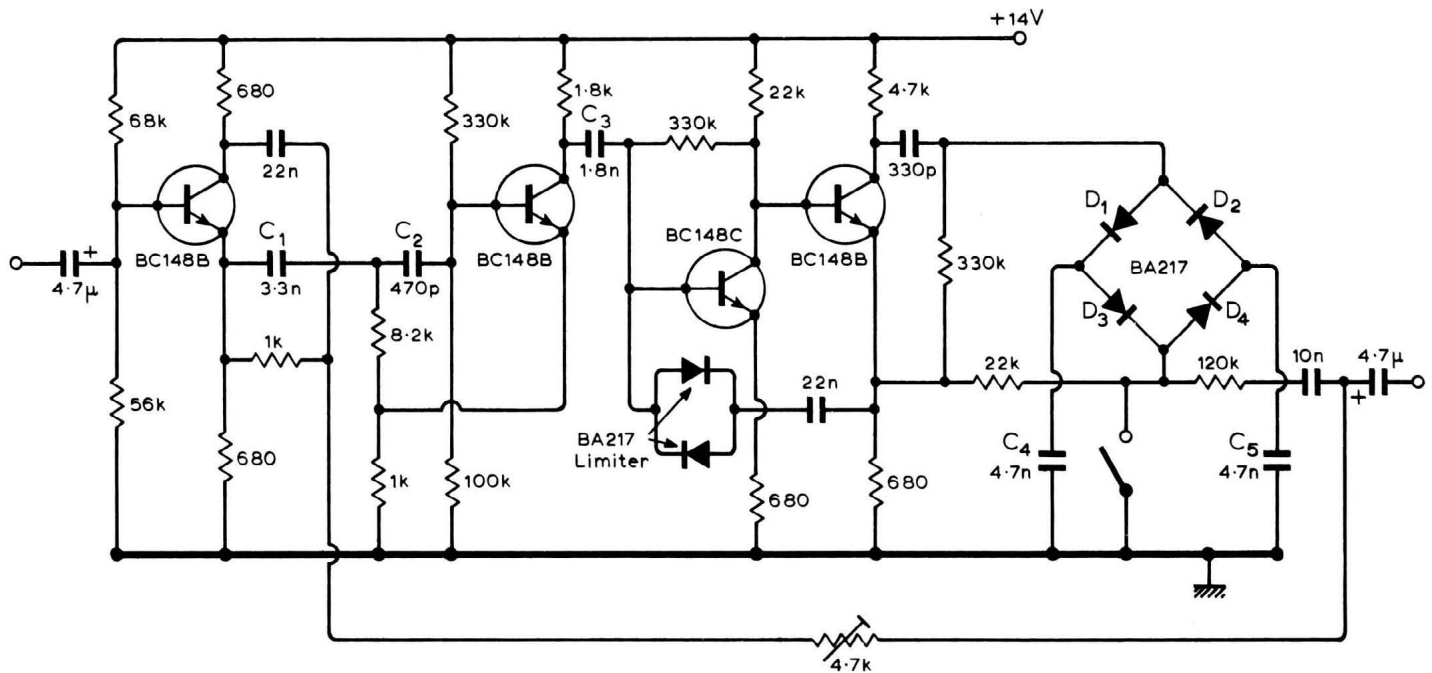

Fig. 2. Complete circuit of Philips dynamic noise reducer. Capacitors C_1 , C_2 and C_3 form part of the high-pass filter. Diodes D_1 and D_2 and capacitors C_4 and C_5 form a peak detector providing a control potential to attenuator diodes D_3 and D_4 .

compatible because the two channels normally require different processing.) An add-on unit is expected to be available in March or April 1972, costing £12-13. The existing cassette machine N2503 will be produced with the noise limiter, to be called N2506 and costing £4 or £5 extra. Philips are offering their circuit – shown in Fig.3 and in simplified form in Fig.4 – on a royalty-fee basis to manufacturers using the cassette system.

Four-channel systems

The newest thing to the exhibition this year was the 'surround sound' and quadraphonic equipment. It was however clear that many people are confused by the current four-channel situation. And if there's confusion among visitors (nay, even distributors of equipment) what about the public at large? The confusion is not so much about discrete vs matrixed methods, but between what are misleadingly being called 'matrix' and 'phase-shift' methods of decoding and synthesis, and also about exactly how this is done. In the CBS method* for instance it happens that the locus of the stylus in the 'coded' disc groove can assume a helical path under certain conditions – i.e. one rear channel signal only – and this seems to have thrown some people off balance! The puzzled newcomer to four-channel coding systems is best advised to forget what's happening in the-disc groove. The point is that the four channels of information can be matrixed into two – with or without phase shifting circuitry – and conveyed by any two-channel medium,

cassettes included (one U.S.A. -company is already producing coded cassettes) where there is no equivalent to the stylus monon. So if you find circular, elliptical or helical modulations confusing, forget it – it is merely a consequence of the phase relationships between the two channels.

As regards the confusion between 'matrix' and 'phase-shift' systems, methods that combine more than two signals into two channels without multiplexing or increasing bandwidth are matrix systems. The CBS and Sansui methods use 90° phase shift circuits in addition to matrixing (more details next issue).

Currently there are many equipments, especially from Japanese makers, which use matrices to reproduce in four-loud-speaker format either coded or conventional two-channel discs (latest on the scene is Zenith in the USA). The trouble, of course, is the lack of a standard at present and not all systems are compatible with

one another. For instance a CBS coded disc played through a Sansui decoder produces a left front signal in the left back speaker! What is needed seems to be a universal decoder designed to reproduce any coded information, which, provided the coding system was known e.g. Sansui or CBS (or others for that matter, but at the moment it looks to us as though one or both of these or a new derivative will win), could be switched to the appropriate decoding matrix. We have just heard that Electro-Voice have produced an integrated circuit for decoding which claims to be suitable for all existing matrices, but we do not have details yet.

Of those equipments intended to provide four-speaker sound from conventional two-channel sources (2-2-4 systems), first to be made in the U.K. is the Pye Stereo +2 adapter which puts difference signals in the rear-speakers. (The two rear signals are usually in antiphase

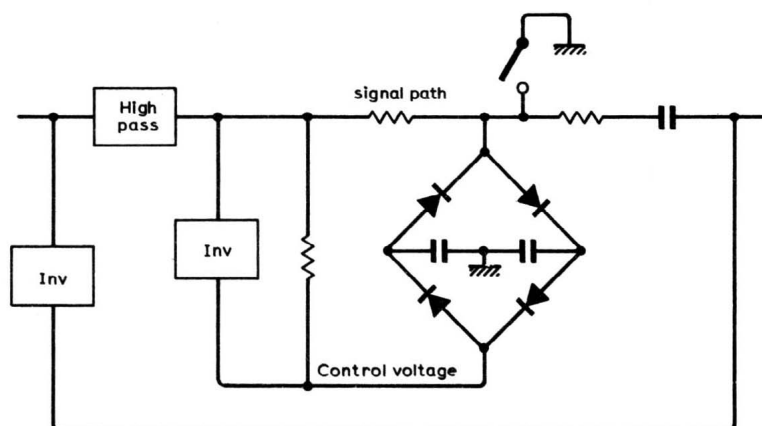

Fig. 3. Simplified diagram of dynamic noise limiter. High-frequency signals from the filter in the auxiliary signal path (top of diagram) partially cancel the h.f. content of the inverted main signal path (bottom) by an amount depending on the h.f. signal level (control voltage).

* 'Quadraphony and home video steal the Berlin show' *Wireless World* October 1971 pp.486-8. This article gives a detailed description of the CBS/SQ matrix system and also discusses some other four-channel systems, including the JVC subcarrier-system.

in this kind of set up, which has been found to be subjectively more satisfactory than in-phase signals. In-phase signals would produce an undesirable well-defined centre back image.) There were seven other makes of such 'surround-sound' equipment shown, some of which introduce cross talk between the two front speakers and some of which put $L - \partial R$ and $R - \partial L$ in the rear speakers, and known under various names like Quadralizer (Pioneer range), Quadriker (Kenwood KA-8044), Quadriker (Sanyo DCA 1700X), sound Field Composer (JVC 5444 and MCA-V7E) and Surround Composer (Onkyo 1631). National and Skandia also showed equipment with a 2-2-4 system, while Sony - who are making equipment for the CBS system - also have their rear-channel-delay system (TA2244). Some of these systems can be used with certain coded discs.

As well as having the matrixed kind of four-speaker distribution (like $L + \partial R$, $R + \partial L$, $L - \partial R$, $R - \partial L$) Pioneer equipment also has a facility for feeding the raw difference signal to the rear loudspeakers with - unlike other systems - a 90° phase difference between them. This has the effect of spreading the image between the two sources. We imagine this might use a simple phase shifter that gives a frequency-dependent phase shift, and if this is so a central image would occur at some frequencies. The JVC models have frequency-dependent rear speaker signals, in that substantially below 300Hz signals are in phase and above are out-of-phase. (Possibly at around 300Hz there is a 90° phase difference here too).

Loudspeakers

Intended for high quality domestic and professional programme monitoring the Acoustic Research AR LST employs nine drive units - four mid-range and treble units and the same bass unit used in the AR3a. There is a control providing several alternative frequency response characteristics (through an auto transformer) including a 'flat energy position'. The price is about £300.

Arthur Radford has improved his Studio 270 loudspeaker by degrees - it is now truly omnidirectional having drivers on all four sides. The units are made by Goodmans. Radiation is through 360° horizontally and 90° vertically from 30Hz to 30kHz. Impedance is 8Ω and power handling capacity 100W. Price £147.50.

JBL demonstrated several new speakers. Their stand was very well worth visiting for their closed demonstration of how monitoring speakers are used in recording studios. The new speakers demonstrated were the L200 Studio 2 (based on monitor model 4320), an efficient bookshelf model the L100 Century, a modernistic looking L45 Flair, and the L55 Lancer.

Besides the two new conventional loudspeaker enclosures - the Havant and

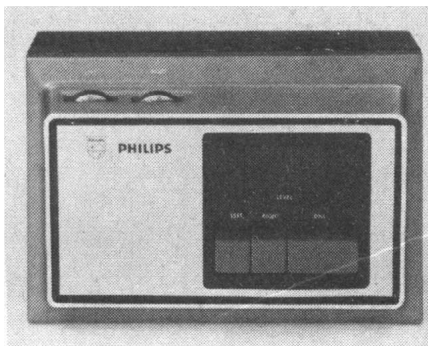

Philips add-on dynamic noise limiter - circuit is shown in Fig. 2.

the Double Maxim - Goodmans have developed a bi-directional enclosure, the Dimension 8. This is a mass-loaded reflex system using a 12in bass radiator cone driven by four 5in bass drivers. The 12in unit comes into operation at 80 Hz. The four small bass drivers cross over at 700 Hz to two mid-range units which cross over at 4kHz to two dome tweeters. A pair of these enclosures, when set up for stereo as intended by the makers is claimed to produce an increased stereo image area because, we are told, the precedent effect (time of arrival of the sound at your ears) tends to be offset by the sound level differences when sitting nearer the axis of the more distant

loudspeaker'. The trouble is that above 1kHz intensity is dominant in establishing stereo images and much of this intensity information is lost by the off-axis position. The Dimension 8 demonstration revealed a deficiency of transient information. This could no doubt be cured by abandoning the 'super stereo speaker angle'.

The Ferrograph speaker designed by Arthur Bailey and demonstrated in his W. W. lecture is a 2.6 cu ft enclosure with a frequency range of 45Hz to 15kHz ± 3 dB. The mid-range and treble units are both made by Goodmans and are exceptionally smooth performers. A section of the crossover notches out the fundamental cone resonance of the tweeter and there are, it is claimed, no remaining resonances in the system. The bass unit is a K.E.F. B139. A long wide wool-filled port pipe is used to achieve low system resonance, the wool fibres contributing to the port mass.

Two new headphone sets are worth mentioning. The AKG K180 is a high quality headset with a 'seat selector' control on each phone which varies the volume between the transducer and the ear. The price is about £30. From Koss the K-711 introduced at Sonex '71 have appeared in a red plastic version named the 'Red Devil'. The transducer system is obviously of very high quality and at £10 a pair is excellent value for money.

Equipment notes

Miniature tape cartridges

A new miniature four-track cartridge has been developed by Pioneer and is backed by a consortium of ten companies, which includes Toshiba, Sharp and Hitachi. Known as Hipac, it is a quarter of the size of conventional eight-track cartridges, measuring only $2\frac{3}{4} \times 3\frac{3}{8} \times \frac{1}{2}$ in. Operating on the continuous-loop principle it requires a simpler mechanism than cassettes. The $\frac{1}{8}$ in tape can be played at $3\frac{3}{4}$ in/sec if required as well as $1\frac{7}{8}$ in/sec. An adapter allows the miniature cartridge to fit existing cartridge players and a tuner

unit is available which slots into the tape player. Cartridges and equipment are in production in Japan, but availability in the U.K. depends on whether record companies adopt the system. Autocar Electrical Equipment Co. Ltd, 1 Lyon Close, Chantry Road, Kempston, Bedford.

Single-play turntable

A single-disc version of the Zero-100 turntable unit is introduced by Garrard. It includes the tangential-tracking pickup of the automatic version (p.237 May issue). Wow and flutter figure is 0.14% peak and rumble is 51dB down relative to 1.4 cm/sec at 100 Hz. Garrard Engineering Ltd, Newcastle Street, Swindon, Wilts.

Tuner-amplifier

New Heathkit tuner-amplifier model AR-2000 is U.K.-designed specially for the British and European markets. Featuring long-, medium- and short-wave bands as well as the v.h.f. band, it gives an output of 20 watts (continuous r.m.s.) per channel. The f.m. tuner features f.e.t.s

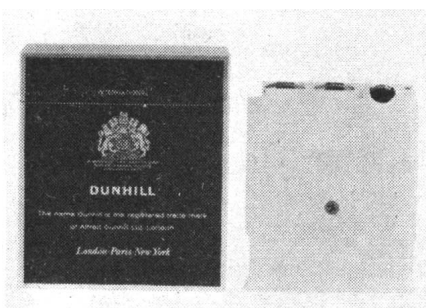

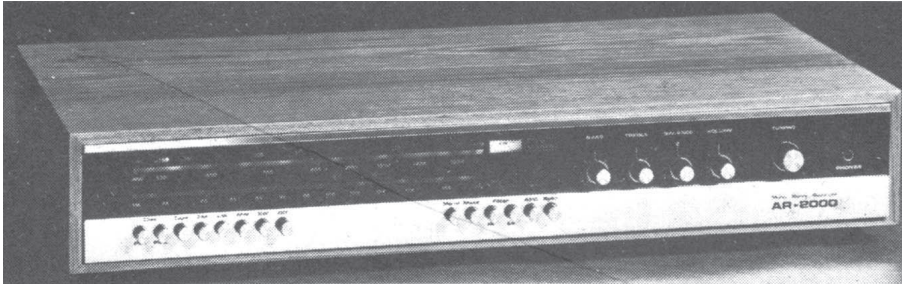

in the r.f. section and new integrated circuits and ceramic filters in the i.f. amplifier. The stereo decoder uses a single i.c. Kit price is about £90 plus £7 for a teak cabinet. Heath (Gloucester) Ltd, Bristol Road, Gloucester GL2 6EE.

Quadraphonic receiver/amplifier

The QR-4500 is one of a new range of Sansui equipment in incorporating the QS matrix. The matrix circuit used, unique to Sansui, has 90° phase shifters to give good quadraphonic performance from Sansui-coded discs and avoids cancellation problems as a result of using phase inverters in certain other matrices. This can also be used as a 2-2-4 system of course for four-speaker reproduction from ordinary stereo sources. Also available are the QS-100 and QS-500 amplifiers, the now well-known QSI synthesizer and a QS6500 receiver, all equipped with the same matrixing system. Vernitron Ltd, Thornhill, Southampton S09 5QF.

Press-button speed change for belt-driven turntable

Connoisseur BD2 turntable is now available with press-button speed change. The 33 and 45 rev/min buttons move the belt mechanically on to the appropriate

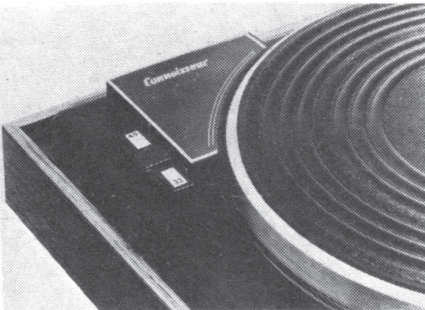

pulley diameter. Specifications of this latest turntable unit are identical with the original unit, e.g. rumble level is given as -60dB measured with the R.I.A.A. characteristic and referred to 7 cm/sec recorded velocity (-43dB re 1cm/sec) and wow and flutter is quoted as 0.1%, presumably "r.m.s.". Suggested price with pickup arm is £32 without plinth and £40 with. A. R. Sugden & Co., Market Street, Brighouse, Yorkshire, HD6 1DX.

Leak amplifiers and tuners

Based on the well-known Leak Stereofetic design, the Delta 75 a.m./f.m. receiver has a sensitivity that permits Continental v.h.f. stations to be received with good quality (2.5µV for 30dB s/n), with harmonic

distortion of 0.5% at full deviation. Image rejection is -72dB and capture ratio 3.5dB. Suppression of 19 and 38kHz signals is at least 40dB. Amplifier gives 35 watts into an eight-ohm load with 0.07% harmonic distortion at 1kHz and all power levels. The a.m./f.m. tuner and amplifier are available separately, and a lower-power amplifier giving 15 watts into an eight-ohm load is available. H. J. Leak & Co. Ltd, Bradford Road, Idle, Bradford, BD10 8SQ.

Quadraphonic cartridge player and receiver

The "Stereo Center" by Skandia (model SK-804) includes a cartridge player for four- or two-channel cartridges and a matrix for "surround sound" from two-channel sources. The tape player accepts either two-channel or four-channel cartridges at 3¾ in/sec and has a fast forward speed of 7½ in/sec. In the two-speaker mode power is 20 + 20 watts (continuous r.m.s.) and 12 watts x 4 in the four-speaker mode. Wow and flutter is 0.42% peak. The a.m./f.m. receiver has good sensitivity and acrosstalk of -26dB at 1kHz. U.K. agents: Golding Audio, London Road, Marks Tey, Colchester, Essex.

Low-power audio combination

As well as catering for high-power levels in the Deccasound range, Decca cater for the low-power end of the market in the new 403 system. It includes 3 + 3 watt (r.m.s.) amplifier, BSR autochanger, and two small loudspeaker enclosures using 5-in dual-cone drivers. Price is about £60. Decca Radio & Television, 9 Albert Embankment, London SE1 7SW.

High-quality cassette recorder

The Uher Compact Report Stereo 124 is fitted with a new four-track head and double capstans to allow automatic



reversing. Low-level amplitude response extends to 12.5kHz (3dB down). Signal-to-noise ratio is quoted as 48dB DIN weighting and 58dB A-curve. Wow and flutter amounts to 0.17% peak. The recorder includes a built-in capacitor microphone with a polarizing potential of only 5V. Power supply can be lead-acid battery, nickel-cadmium battery or from the mains. Price is £182. U.K. agents: Bosch Ltd, P.O. Box 166, Rhodes Way, Watford WD2 4LB, Herts.

Cassette recorder with crystalline ferrite head

A cassette tape machine using a crystalline ferrite GX head, as used on Akai open-reel recorders, is Akai model GXC-40D. It is claimed that head life is up to 100 times that of ordinary heads. The set is equipped with a switch for chromium dioxide tapes which alters bias and the equalization characteristic. As well, there is an "over-level suppressor" switch to prevent overloading on high-level passages — useful if you know over modulation is going to occur. Wow and flutter is less than 0.3% peak and a tolerance of ± 2% is quoted for tape speed. Distortion is 2% at 0V.U. (1kHz) and s/n ratio 48dB. Price: £87.50 deck version. U.K. agents: Rank Audio Visual, P.O. Box 70 Great West Road, Brentford, Middx.

In brief

- Both Ferrograph and Revox demonstrated versions of their tape recorders incorporating the Dolby B noise reduction system.
- Goodmans revealed a professional tape recorder, the R73, which employs twin capstans and has switchable NAB or DIN 45:513 equalization. There are two speeds — 15 and 7½ in/sec. or 7½ and 3¾ in/sec.
- The Beocord 1200 tape deck from Bangand Olufsen is a two-speed four-track unit with slider mixing controls. Frequency response is to DIN 45:500 for 7½ and 3¾ i.p.s. Distortion is < 5% from a fully modulated tape. Signal-to-noise ratio is high, and erase capability is > 70dB. Recommended tape is BASF LP 35LH. Model 1600 has a built-in stereo amplifier delivering 10W r.m.s. per channel, but is otherwise the same as the 1200.
- Goldring revealed two new turntable units — the GL85 and G101. The GL85 is a belt-driven turntable with pick-up arm. Fine speed adjustment is electronically controlled. At the end of the record, current is switched off and the arm raised from the record surface. The G101 is a compact turntable/pick-up arm unit, also belt driven, and having an adjustable antiskating device.