

QUAD 405 Evolution
September 2011

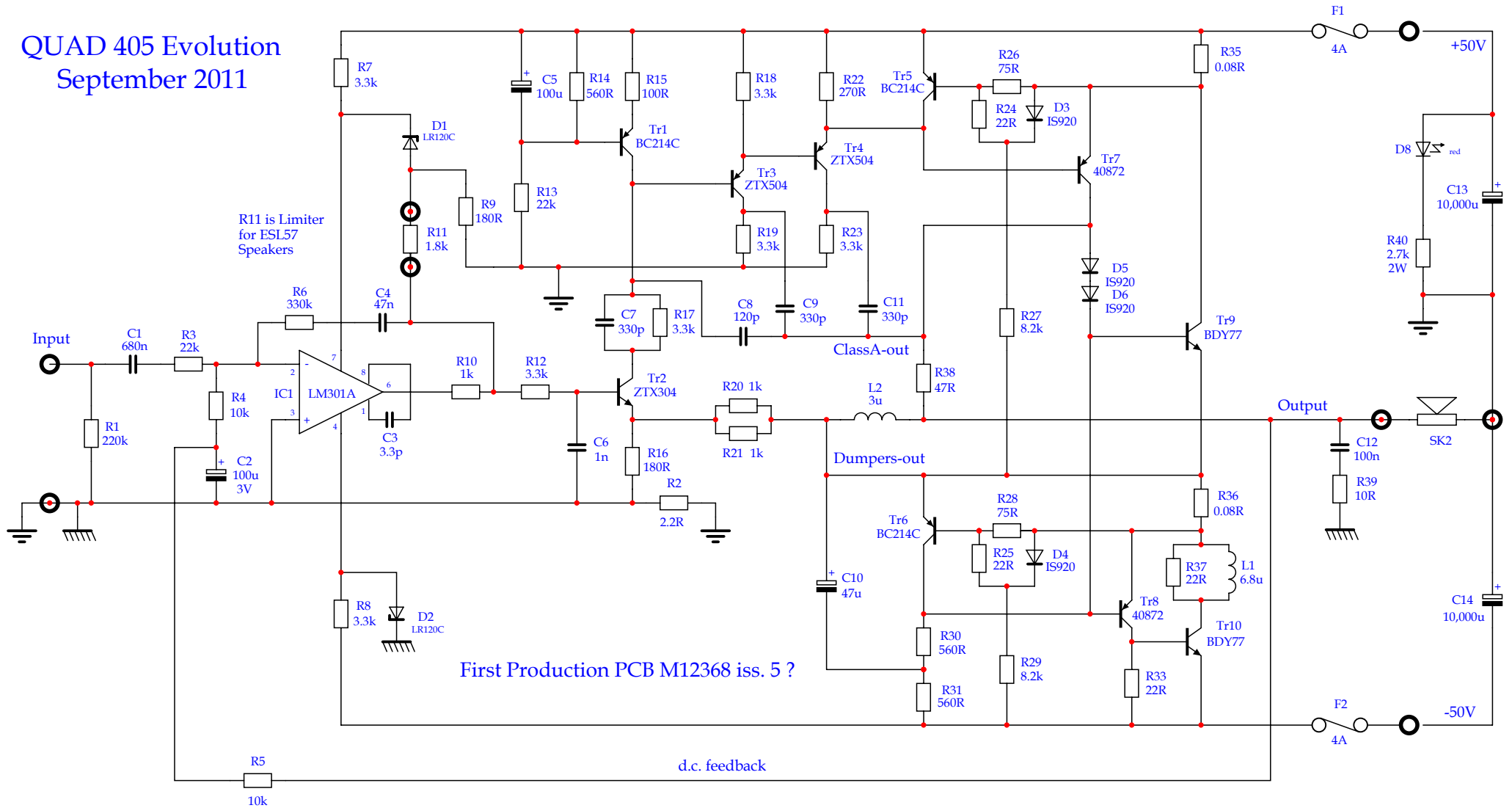

QUAD 405 Schematic as published in Wireless World Dec.1975
to support the article "Current Dumping Audio Amplifier"
by P J Walker of the Acoustic Manufacturing Co. Ltd. (Q.U.A.D.)

Revision: 2	keith@snook.eu	Page Size: A4
QUAD 405 M12333 iss. 2		
2 Mar 2002	Drawn: K. Snook	Checked:
		Page 1 of 1

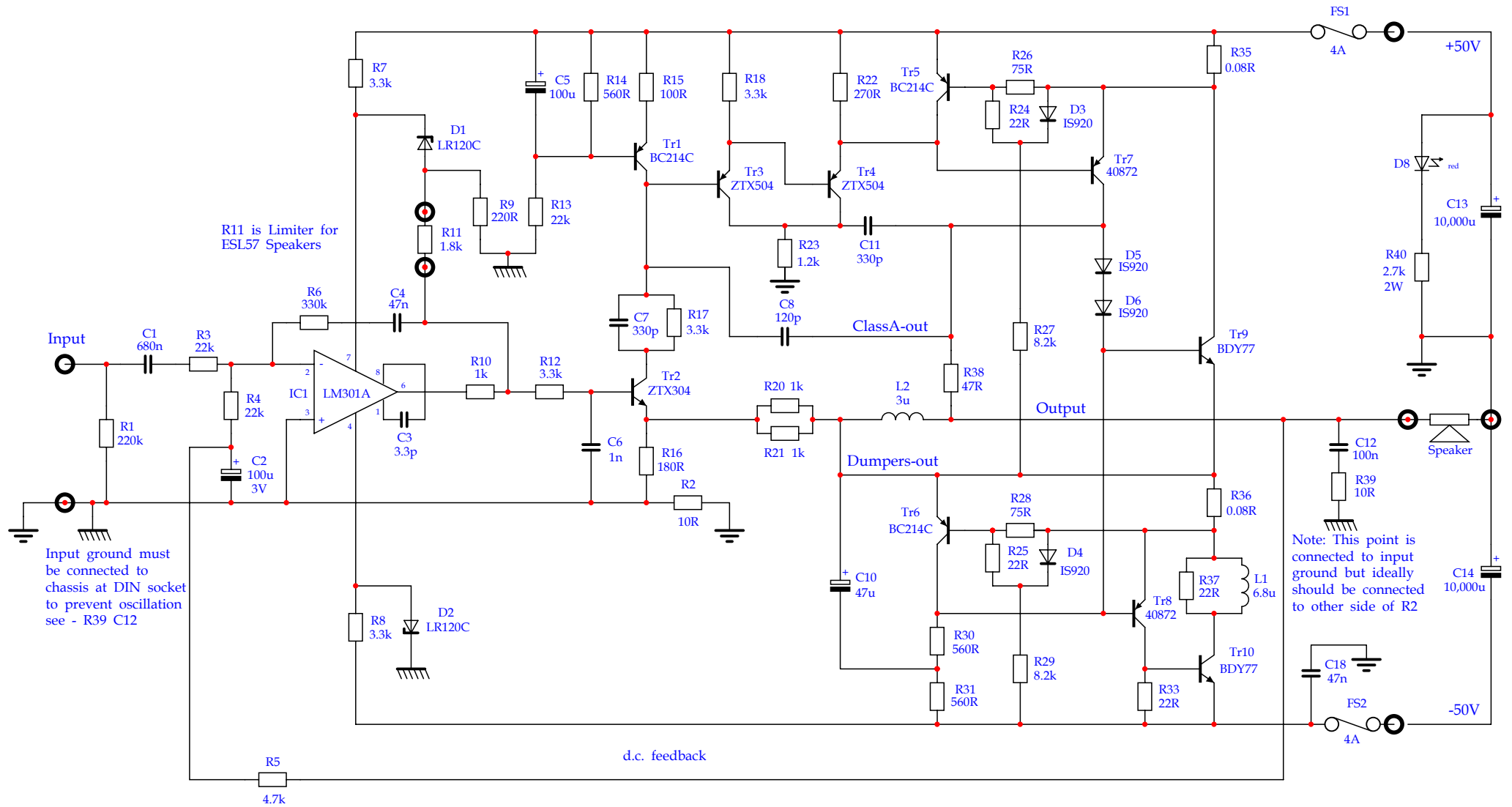

M12368 iss. 7 PCBs were used for serial numbers from ?? to 9000

Revision: 1	keith@snook.eu	Page Size: A4
QUAD 405 - M12333 iss. 3		
8 Feb 2003	Drawn: K. Snook	Checked:
		Page 1 of 1

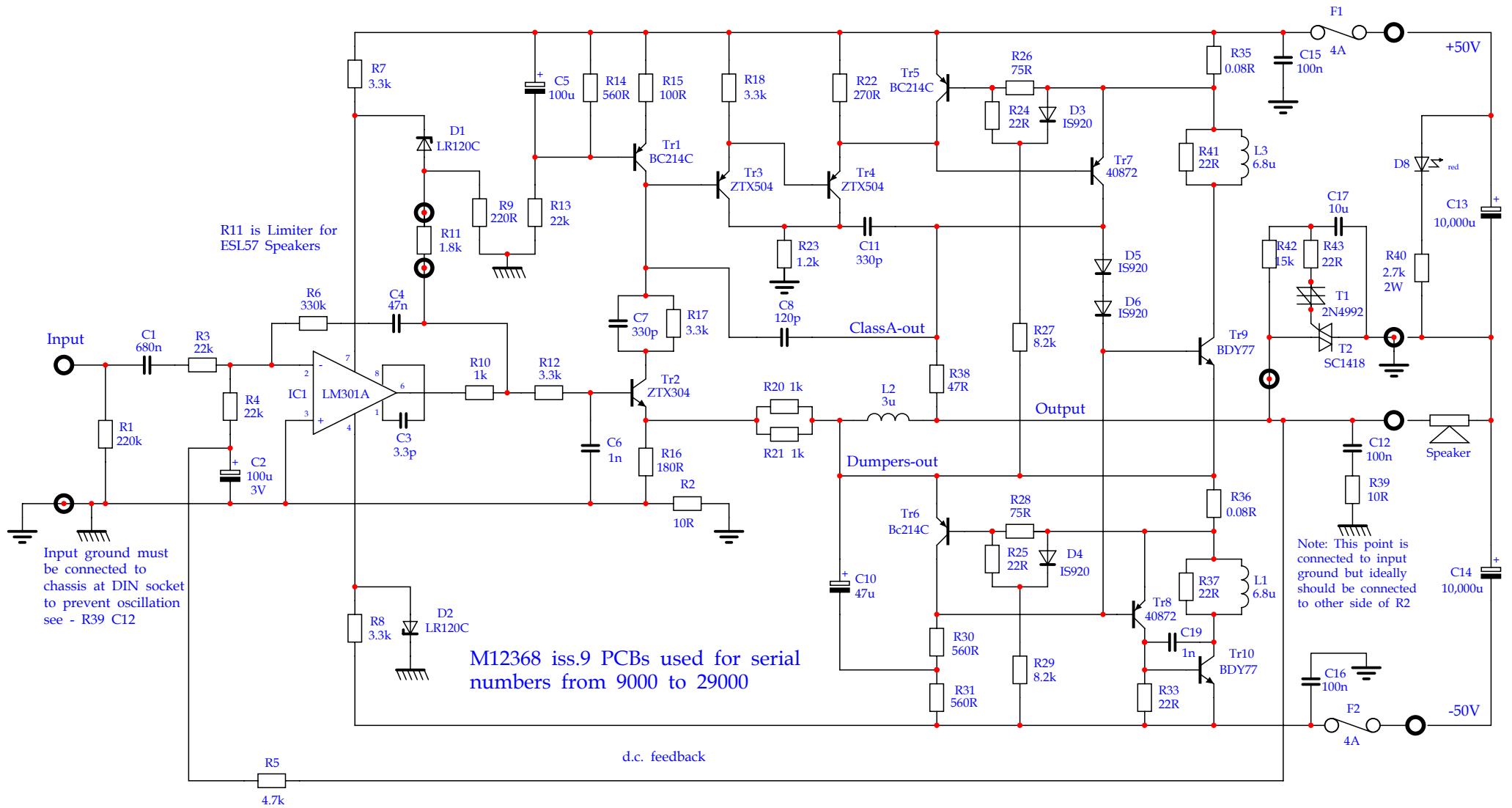

Revision: 1	keith@snook.eu	Page Size: A4
QUAD 405 - M12333 iss. 4		
8 Feb 2003	Drawn: K. Snook	Checked:
		Page 1 of 1

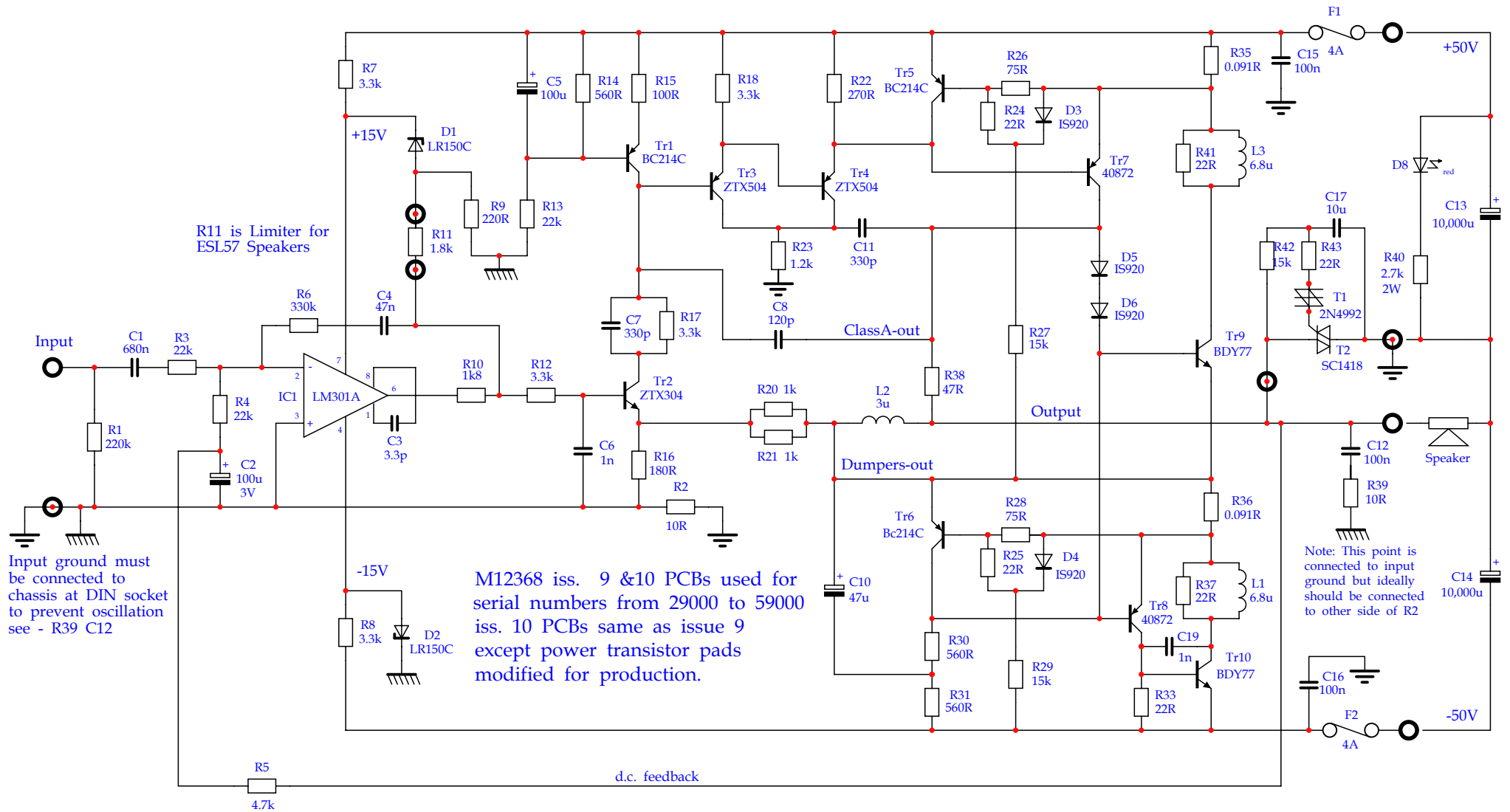

Revision: 2	keith@snook.eu	Page Size: A4
QUAD 405 - M12333 iss. 5		
8 Feb 2003	Drawn: K. Snook	Checked:
		Page 1 of 1

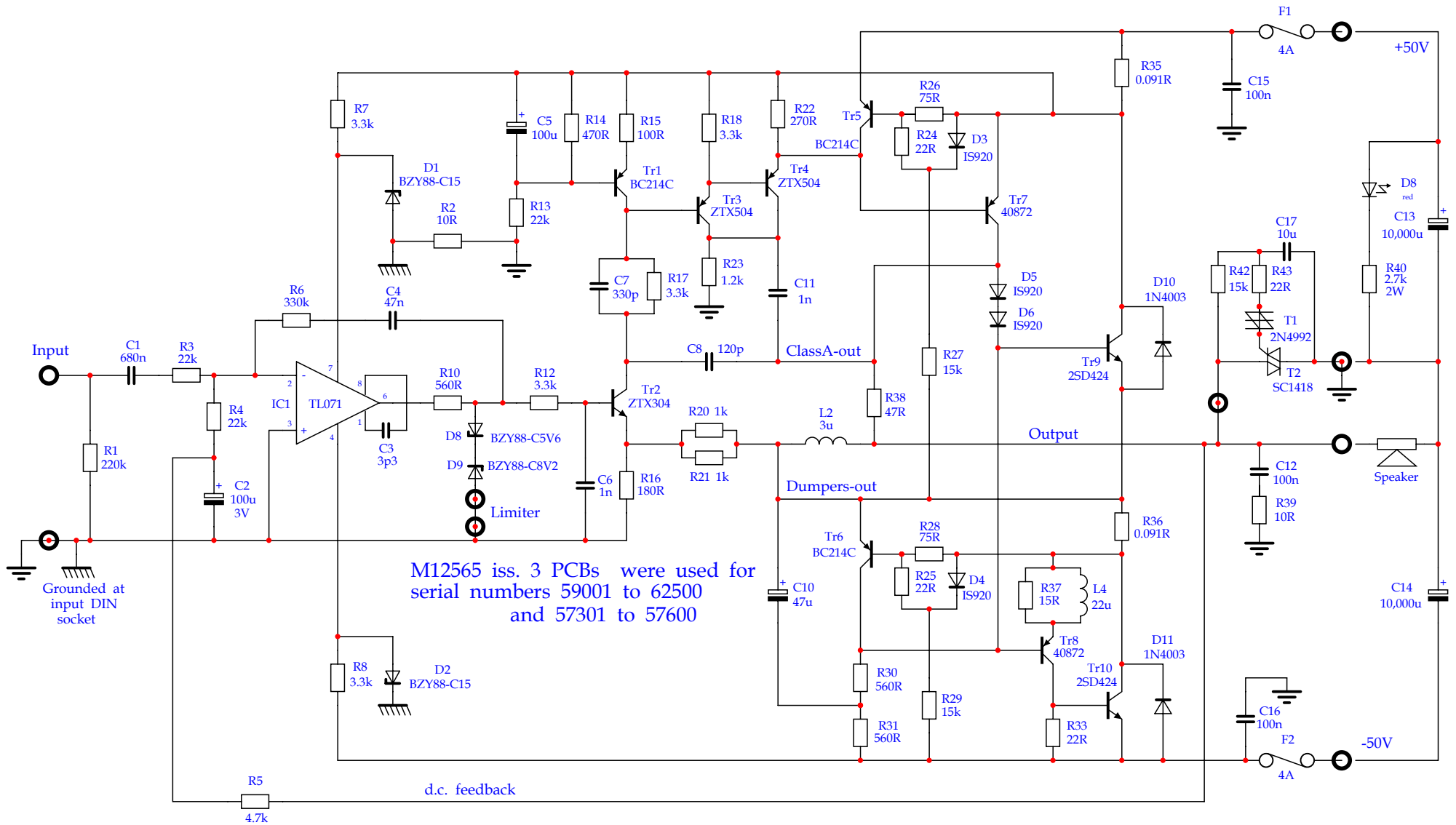

Revision: 2	keith@snook.eu	Page Size: A4
QUAD 405 - M12333 iss. 6		
12 March 2004	Drawn: K. Snook	Checked:
		Page 1 of 1

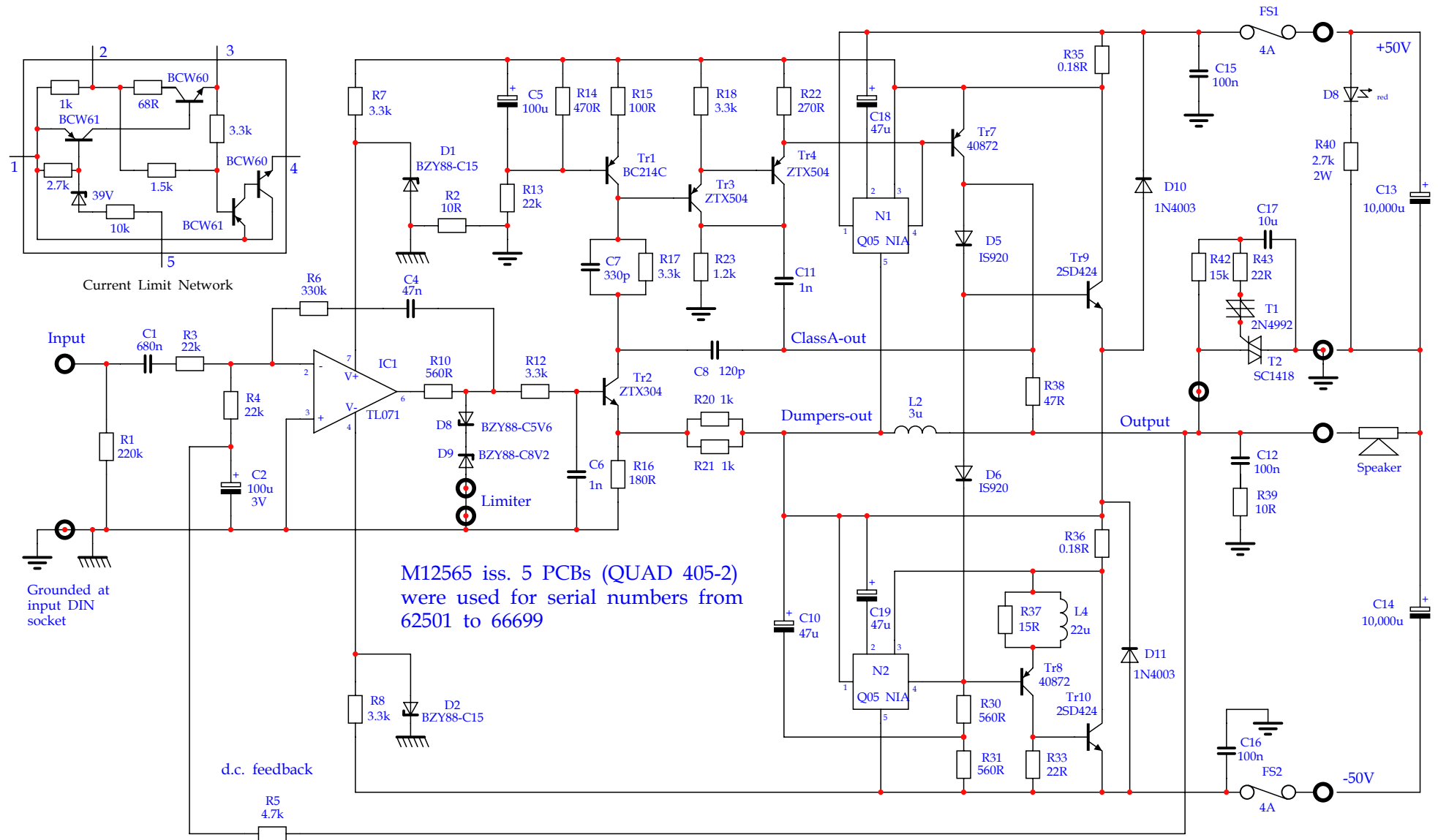

Revision: 1	keith@snook.eu	Page Size: A4
QUAD 405 - M12333 iss. 7		
8 Feb 2003	Drawn: K. Snook	Checked:
		Page 1 of 1

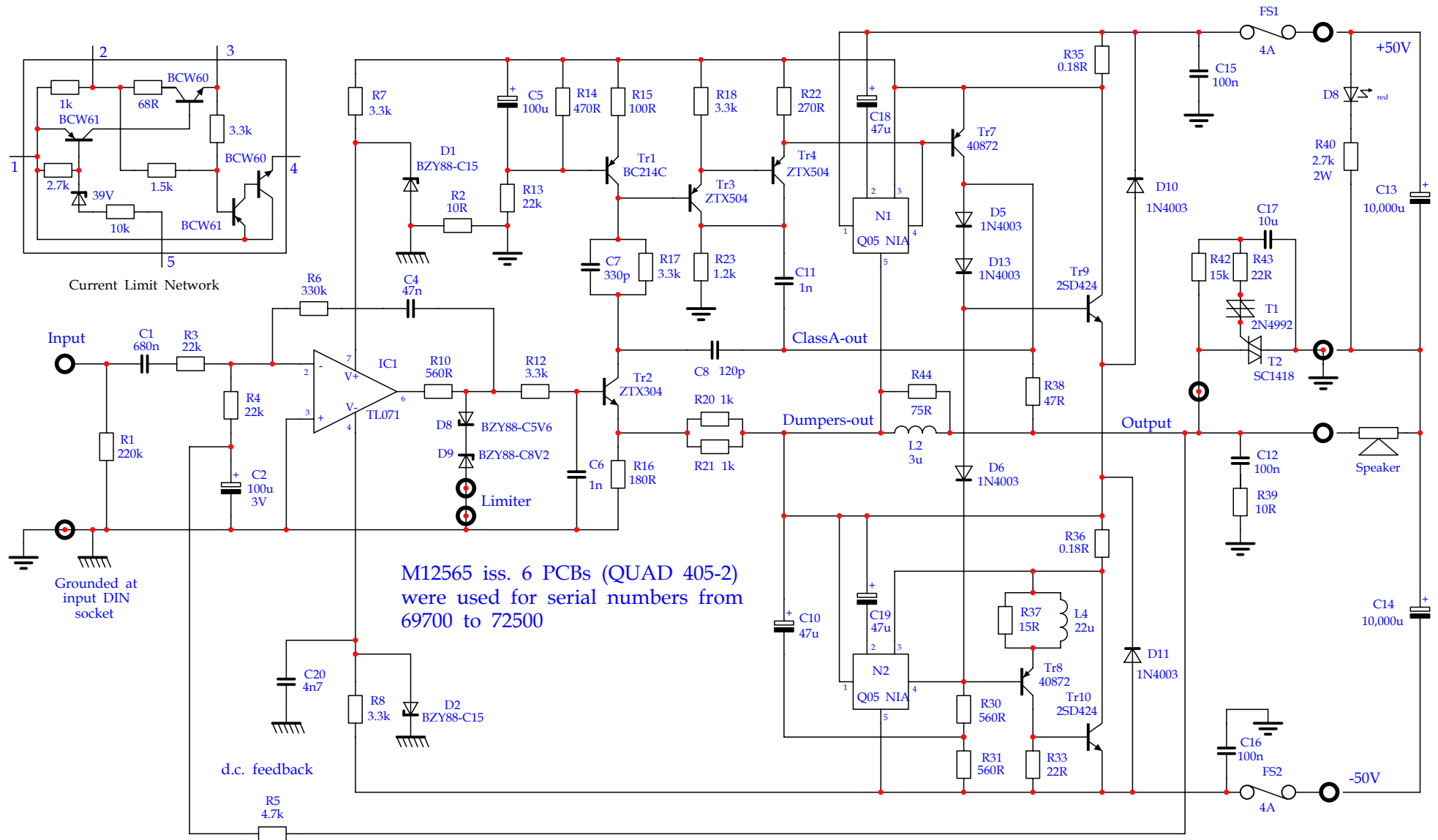

Revision: 1	keith@snook.eu	Page Size: A4
QUAD 405 - M12333 iss. 8		
8 Feb 2003	Drawn: K. Snook	Checked:
		Page 1 of 1

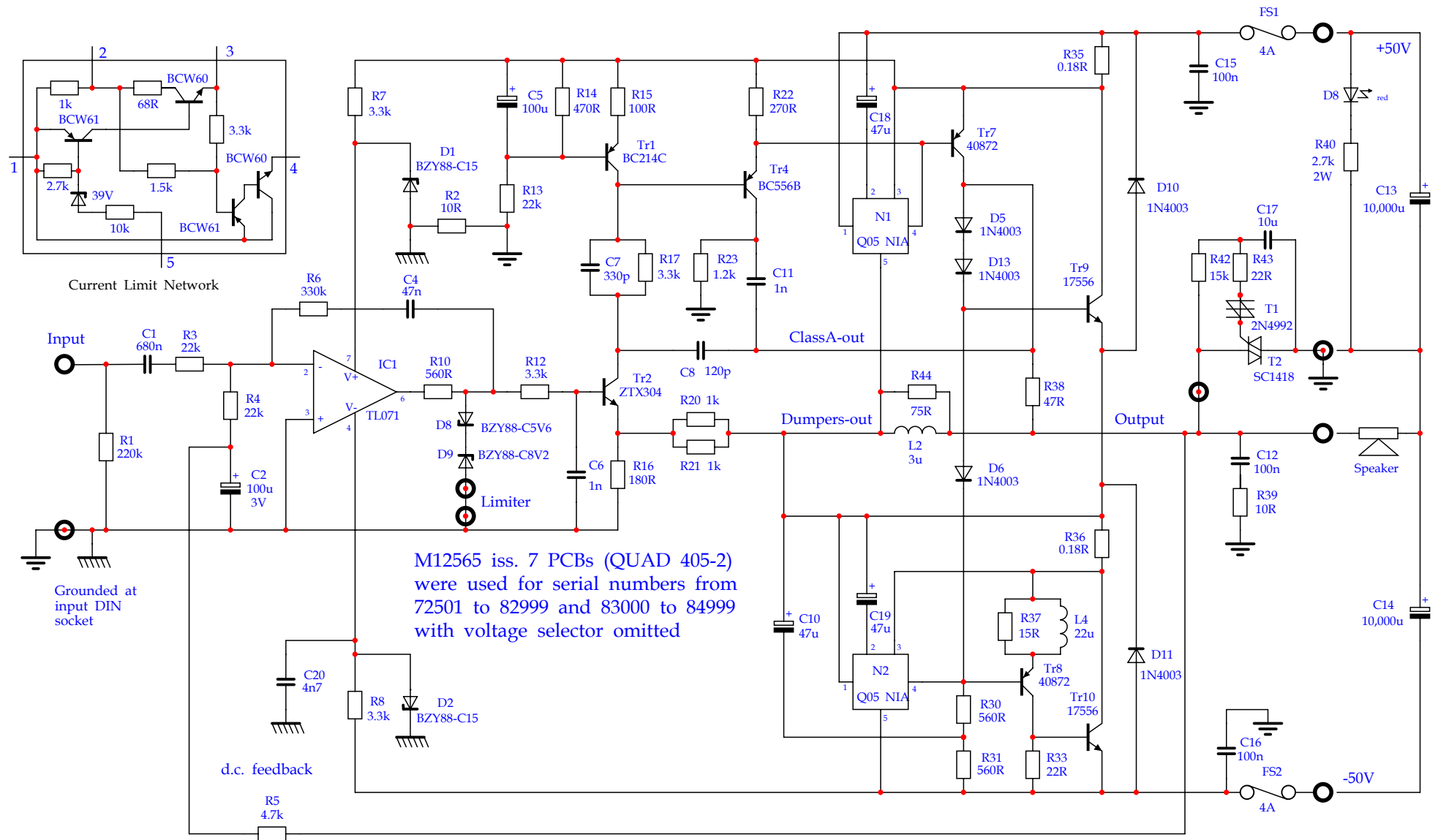

Revision: 1	keith@snook.eu	Page Size: A4
QUAD 405 - M12333 iss. 9		
12 Feb 2003	Drawn: K. Snook	Checked:
		Page 1of 1

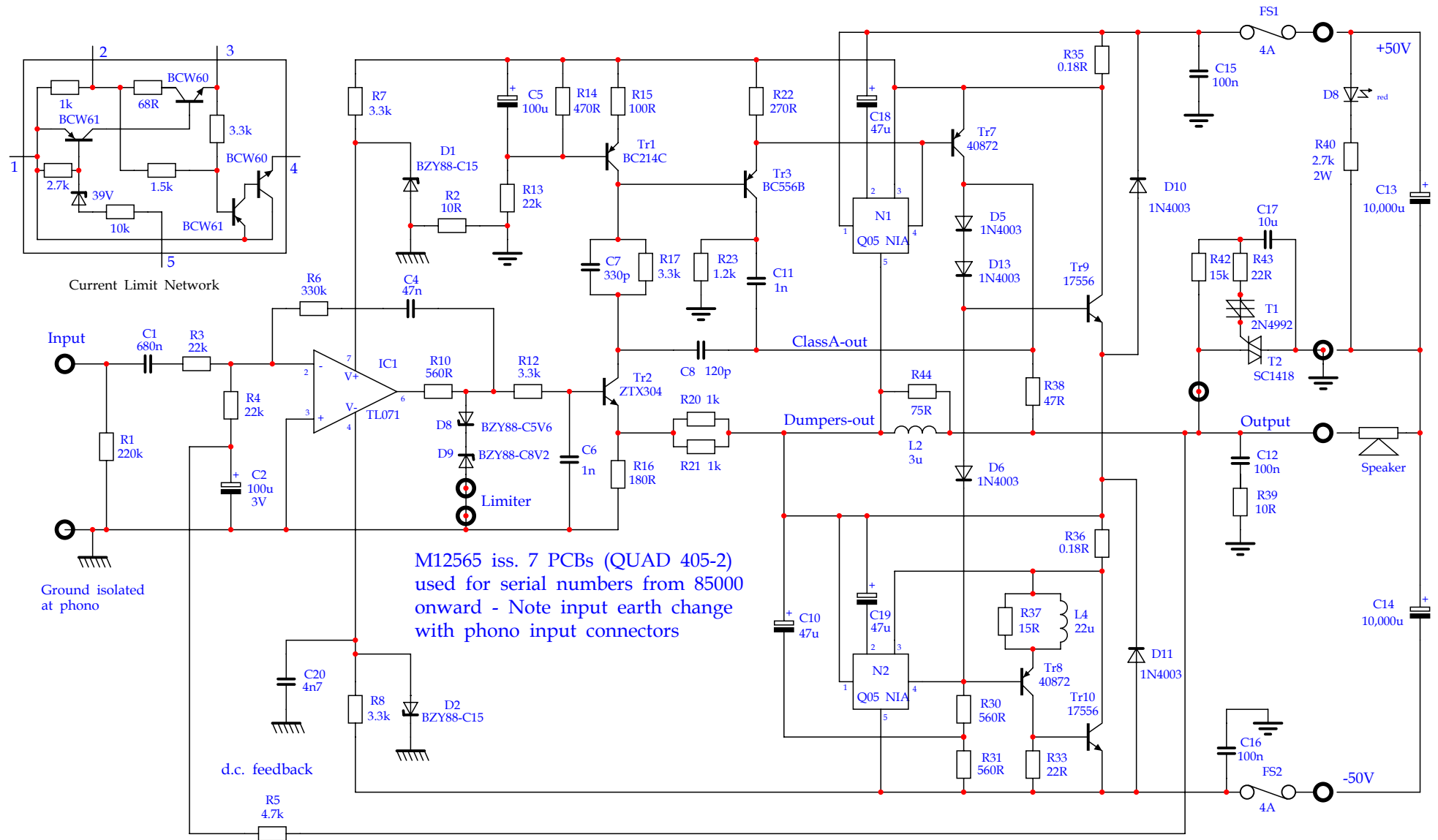

Revision: 3	keith@snook.eu	Page Size: A4
QUAD 405 - M12333 iss. 10		
12 May 2004	Drawn: K. Snook	Checked:
		Page 1of 1

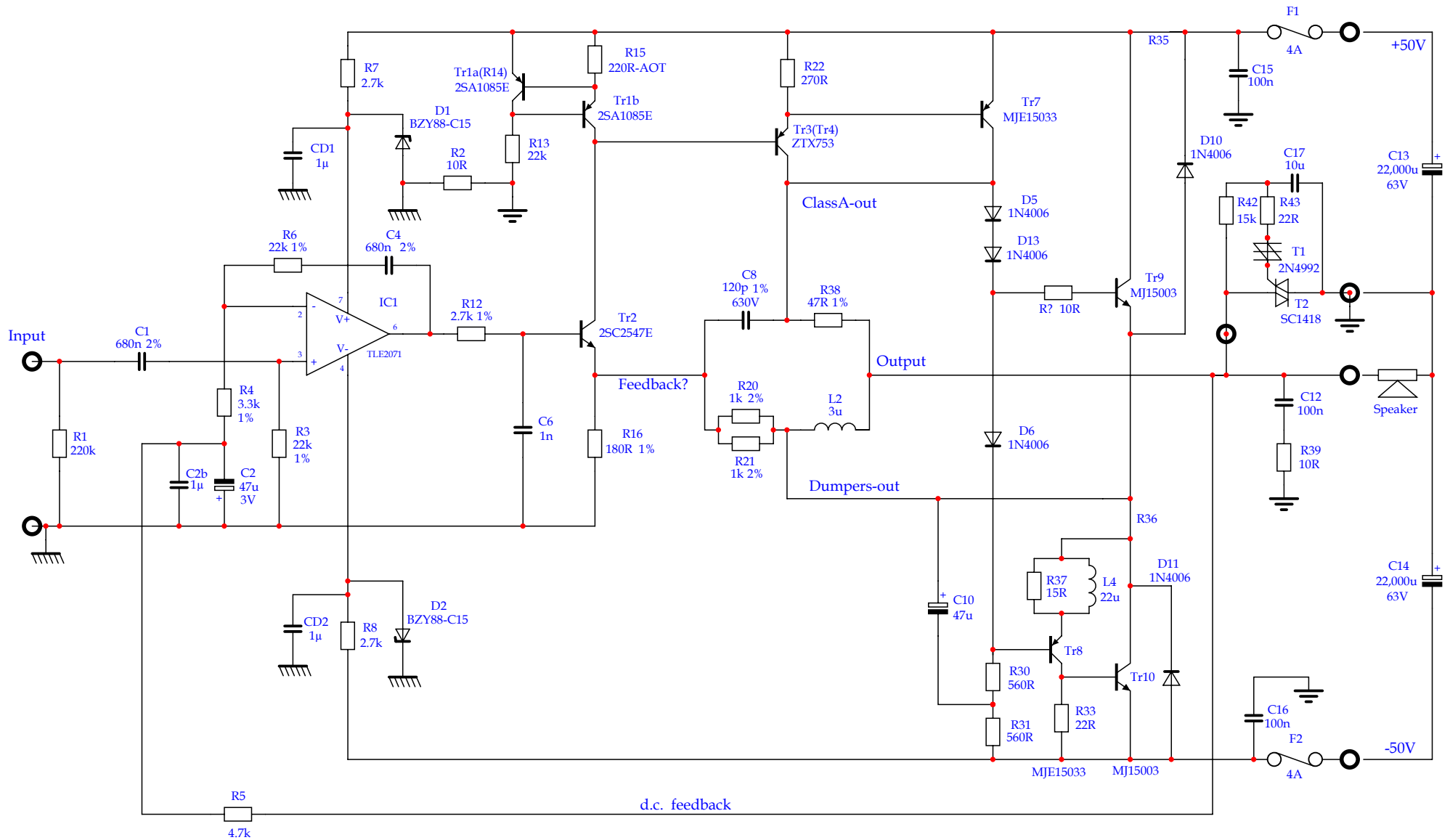

Revision: 6	keith@snook.eu	Page Size: A4
QUAD 405 - DCD Mod-3		
Sept 2011	Drawn: K. Snook	Checked:
		Page 1 of 1

Components marked in green are changes or additions to the original n.f. = not fitted and Link = remove and wire across.

For original sensitivity 0.5V for 100W fit R4 = 1.6k and C2 = 100uF

As shown sensitivity is 1V for 100W

For sensitivity of 1.5V for 100W fit R4 = 4.7k and C2 = 33uF

Tr3 should be bypassed base-emitter as shown and it should then be possible to safely remove C19 fitted across Tr10 collector-base on the solder side of the PCB - If you are not sure bypass Tr3 and leave C19

Components marked in grey with blue reference designators may be removed to disable current limiting - This should be done with caution and preferably after Tr9 and Tr10 are changed to higher power devices like MJ15003

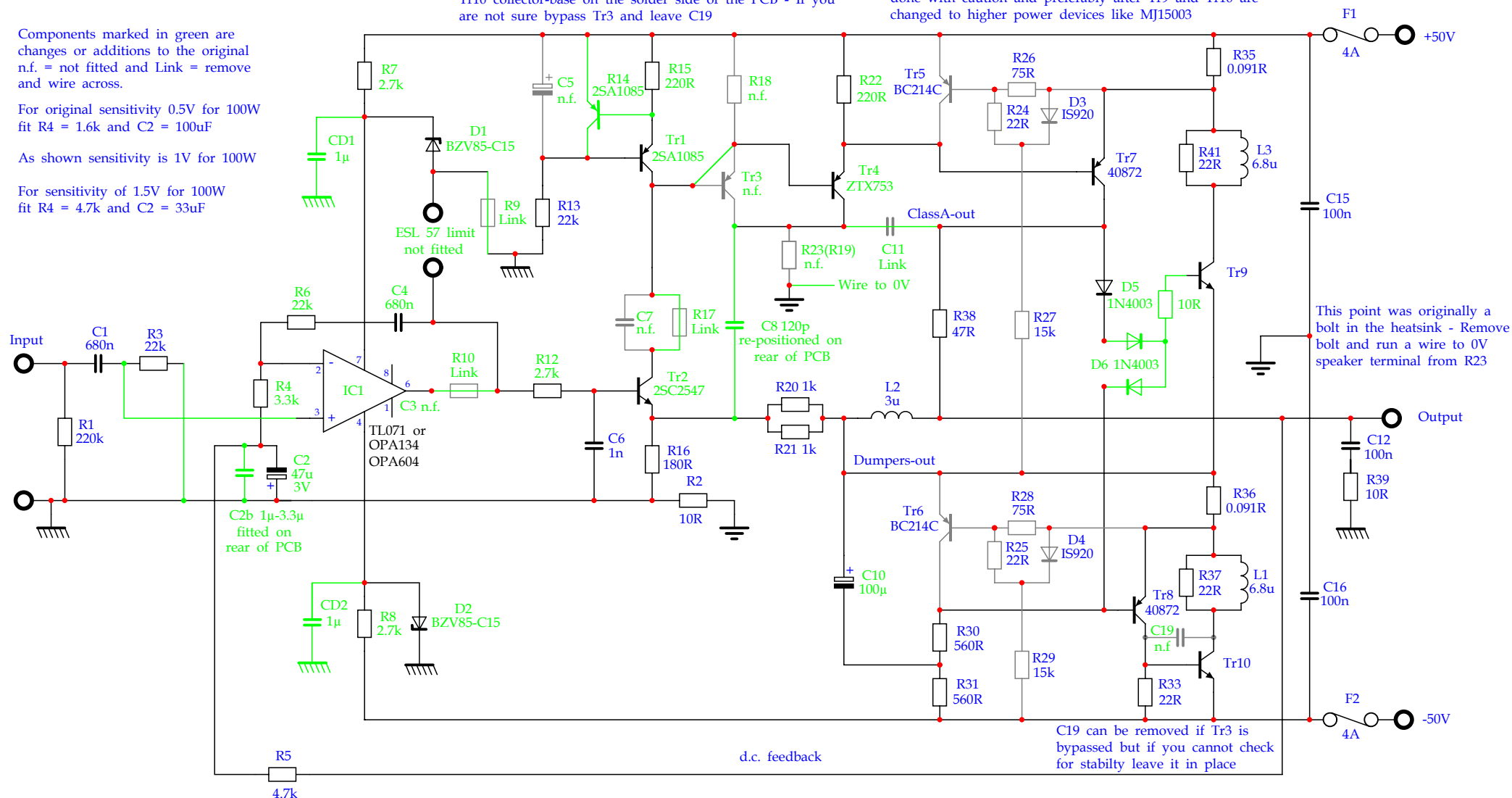

This point was originally a bolt in the heatsink - Remove bolt and run a wire to 0V speaker terminal from R23

d.c. feedback

C19 can be removed if Tr3 is bypassed but if you cannot check for stability leave it in place

Note the 2 different ground symbols either side of R2 - probably to prevent internal hum loops - The input ground connects to the chassis at the input DIN socket and originally the other side of R2 connects to chassis via the bolt in the heatsink - Even if you do not provide a formal ground wire to the 0V speaker terminal as I show you should ensure that both sides of R2 are at the same potential - If one ground is missing the voltage at the speaker terminals will be about 20mV if both grounds are in place it should be less than 1mV - Both grounds should be connected to chassis

Revision: 3	keith@snook.eu	Page Size: A4
<h1>M12368 PCBs to DCD Mod-3</h1>		
1 Sept 2008	Drawn: K. Snook	Checked:
		Page 1 of 1

Note: This is only a schematic - It has been implemented as a mod to 12368 iss.10 and 12565 iss.7 PCBs but the circuit can oscillate at VHF radio frequencies which do not appear at the output but can put the transistors in compression - increasing the distortion and dissipation

lookout for updates and refer to my website for further information

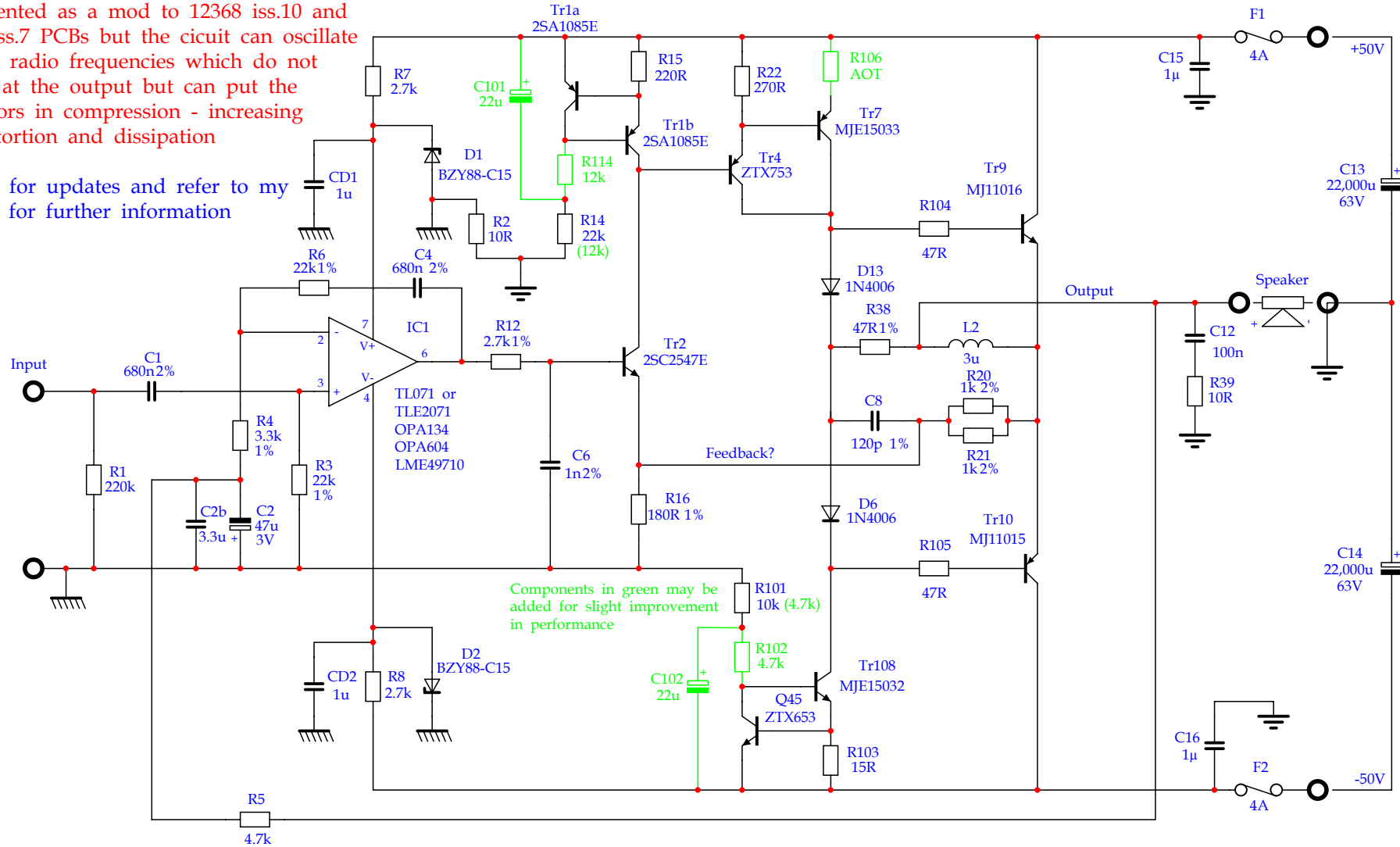

Components in green may be added for slight improvement in performance

Note: The "Current Dumpers" Tr9 and Tr10 are complimentary Darlington transistors – This layout WILL NOT work with low hfe output devices due to the base current required – The "Current Dumpers" can be made complimentary MOSFETs If D13 and D6 are changed for resistors but care must be taken to ensure that the Source-gate voltage can be obtained within the limits of Tr7 and Tr108 current drive

Revision: 2	keith@snook.eu	Page Size: A4
QUAD 405 - DCD Mod-4		
19 Mar 2005	Drawn: K. Snook	Checked:
		Page 1 of 1