

circuit diagram

M12746 iss 2 onward

For Serial Numbers 6001 to 8000 PCB No M12730 iss 4 With additional information to support Keith Snook QUAD 34 mods and for QUADs own input buffer mod from S/N 8001 onwards

QUAD 34

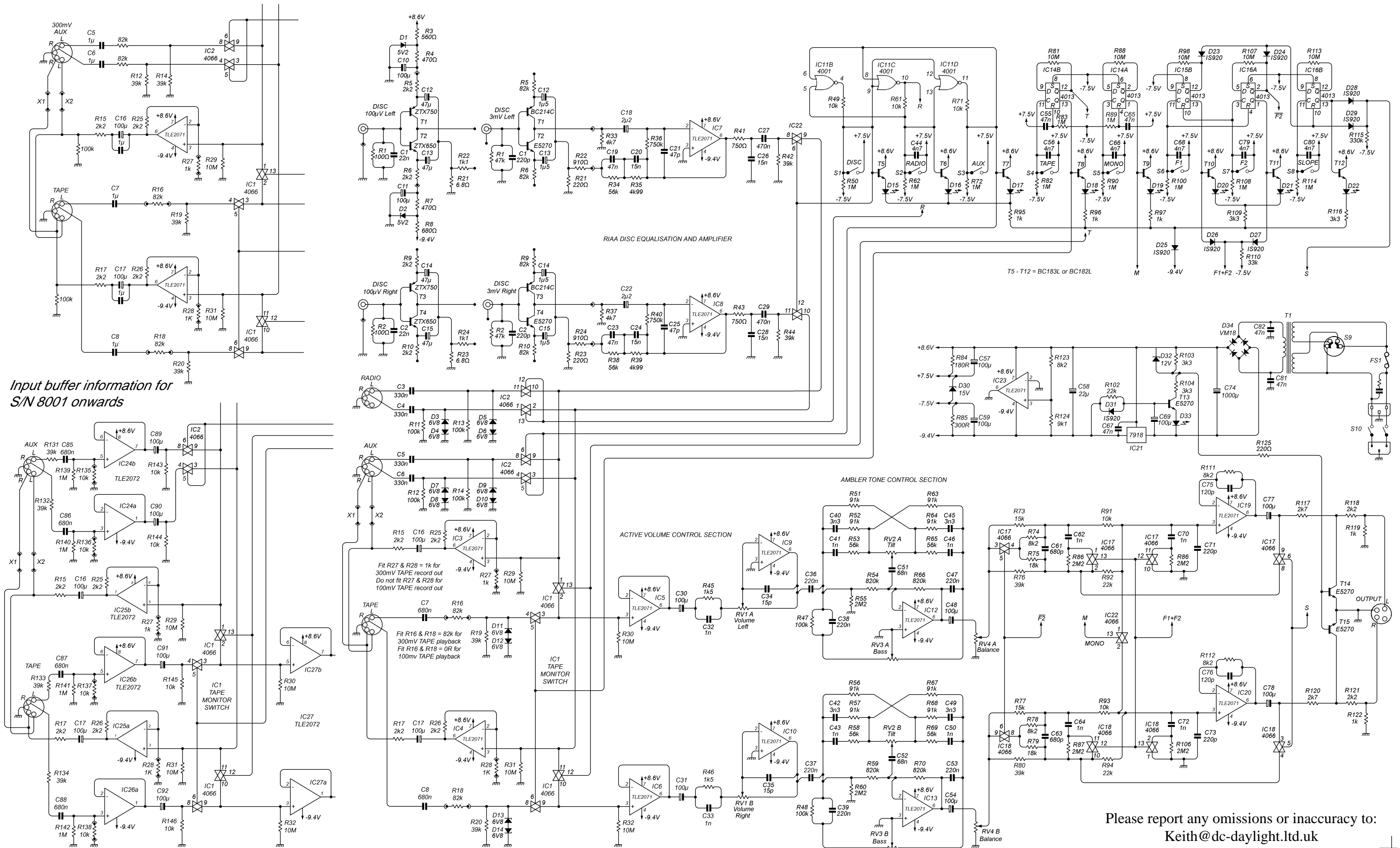

Please report any omissions or inaccuracy to:
Keith@dc-daylight.ltd.uk