

Note: R5 and R6 values are marked as found but are wrong - Both should be the same value ? This appears to be copied - incorrectly - from the LEAK or BBC type phase splitter which is not directly coupled from the previous stage

Note; V3 and V4 are shown as KT66 but valves fitted were the underated 6Y6

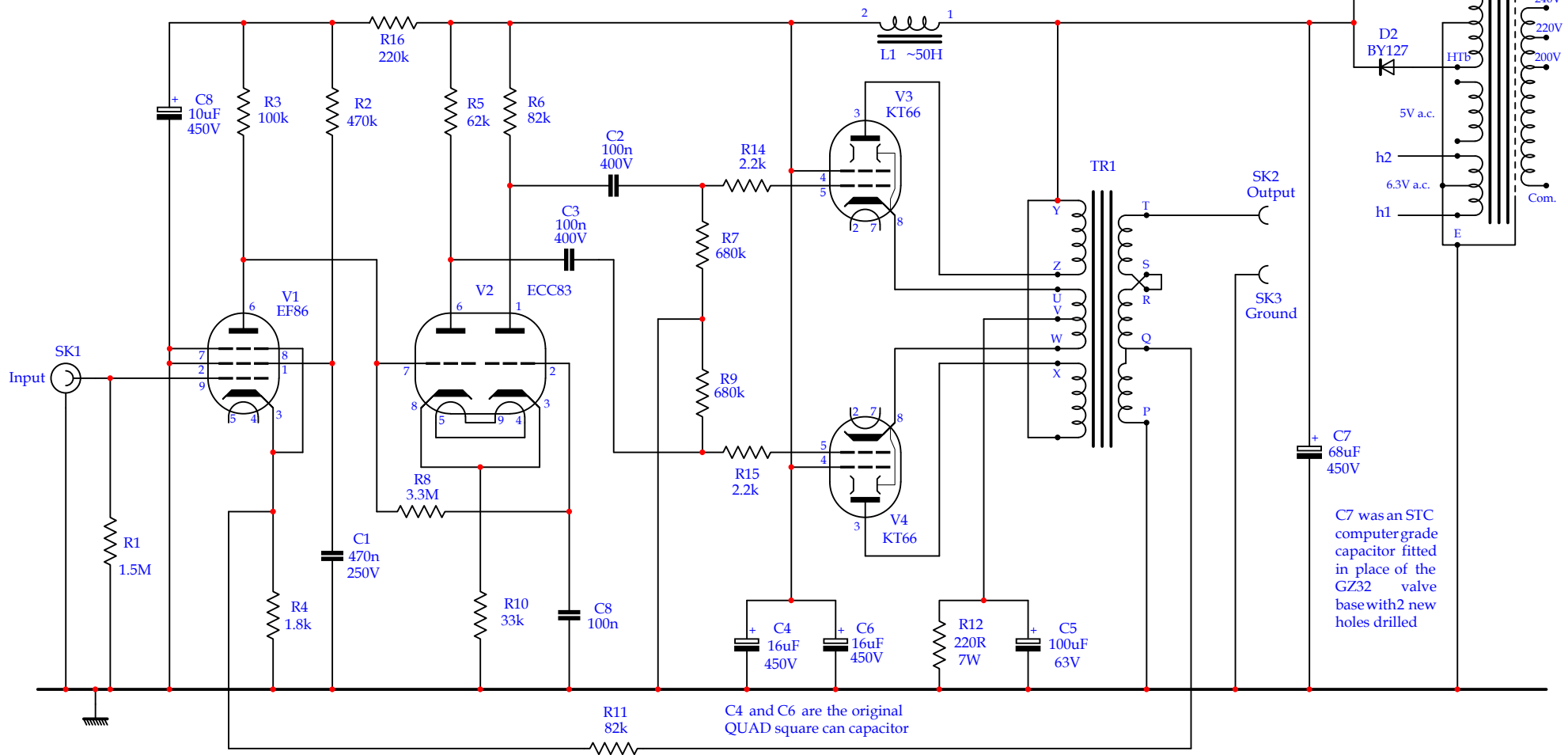

C7 was an STC computer grade capacitor fitted in place of the GZ32 valve base with 2 new holes drilled

C4 and C6 are the original QUAD square can capacitor

Note: This schematic is for information only - I DO NOT recommend this is done to any QUAD II

see <http://www.keith-snook.info>

Revision: 2	<i>Keith Snook .info</i>	Page Size: A4	<i>iss. 2 R10 value and R16 position</i>
<b>QUAD II Concordant modified ?</b>			
8 Feb 2005	Drawn: K. Snook	Checked:	Page 1 of 1