

The Following information is based on PCB type M12565 iss.3 The layout can be applied to other versions but the instructions below may not relate.

Cut track to op-amp pin 3 close to pin, remove link pins and zenner diodes D8 and D9.

Replace R10 with wire link, fit new values for R4, R6 and C4.

Fit new R3 standing upright such that it bridges R4 and fits between end of C1 and the hole to ground where the link pin was.

Fit wire link from op-amp pin 3 to junction C1/R3 this can follow a path against a ground track.

Changing R12 to 2.7k increases the frequency response to about 59kHz, this may not be suitable where the dumpers are "slowed down" in other versions of the design.

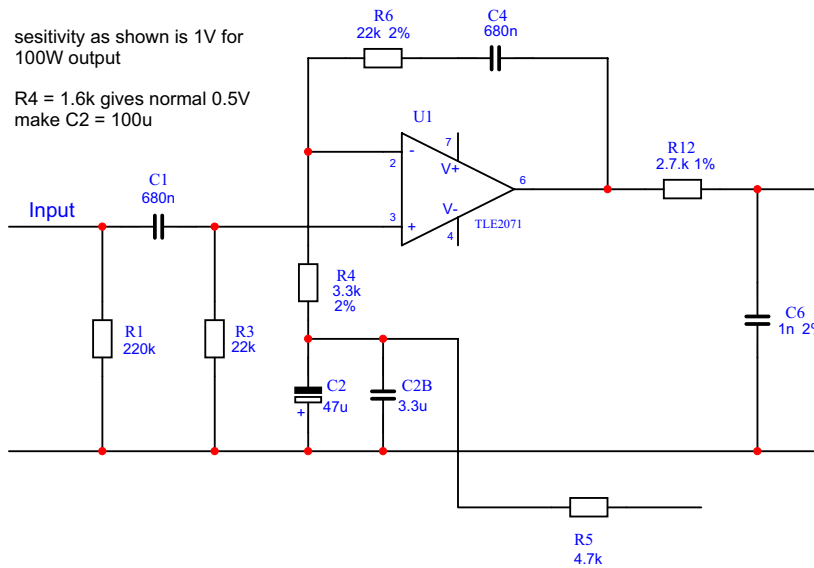

Revision: 1	d.c. ~ daylight ltd.	Page Size: A4	d.c. ~ daylight ltd.
QUAD 405 new non-inverting input			5 Greenacre Drive Pontprennau Cardiff CF23 8PA
8 February 2004	Drawn: K. Snook	Checked:	Tel: +44 29 20 657149 Fax: +44 29 20 657151
		Page 1 of 1	